

PEDRALI S.p.A.
sp 122 Mornico al Serio - 24050 BERGAMO - ITALY
Export Dept. Tel: +39 035 8358840 Fax +39 035 8358888
Ufficio Commerciale Italia Tel: +39 035 8358810 Fax +39 035 8358888

www.pedrali.it - info@pedrali.it

SUPERPLASTIC_1411

PEDRALI

SEDUTE

SUPERPLASTIC 2014

PEDRALI[®]
DYNAMIC DESIGN

SUPERPLASTIC 2014



SUPER**PLASTIC** 2014

Ara p. 44		Miss and Mrs Alù p. 216	
NEW Babila p. 52		Miss_You p. 108	
Blitz p. 92		Mya p. 70	
Day Dream p. 102		UPDATE Noa p. 24	
Enjoy p. 88		Pasha p. 112	
Gliss p. 142		Plus p. 174	
Gliss Lounge p. 156		Plus Air p. 184	
Gossip p. 132		Queen p. 124	
Grace p. 82		Smart p. 212	
Host Lounge p. 220		Snow p. 32	
Ice p. 200		NEW Snow Jr p. 42	
Joi p. 64		Tatami p. 190	
Koi-Booki p. 58		UPDATE Tweet p. 12	
Kuadra p. 164		UPDATE Volt p. 04	
Kuadra XL p. 160		Wow p. 224	

04 Volt

Design Claudio Dondoli and Marco Pocci



Art. 670 - 675

Il tratto sottile e lineare, le gradevoli proporzioni e i colori freschi rendono Volt una seduta che si distingue per la cura dei dettagli. Realizzata in polipropilene rinforzato con fibre di vetro e stampato ad iniezione con gas air moulding, Volt è disponibile nei colori bianco, nero, rosso, grigio antracite, beige, giallo, blu.
 The thin and linear design, the graceful proportions and fresh colours make Volt a sitting that stands out for its attention to details. Made of injection gas air moulding polypropylene reinforced by fibers glass. Colours: white, black, red, anthracite gray, beige, yellow, blue.

colori / colours:

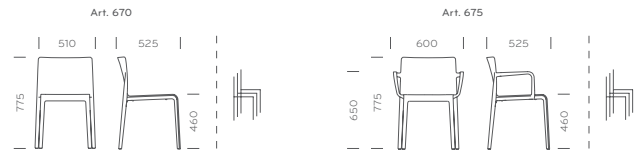
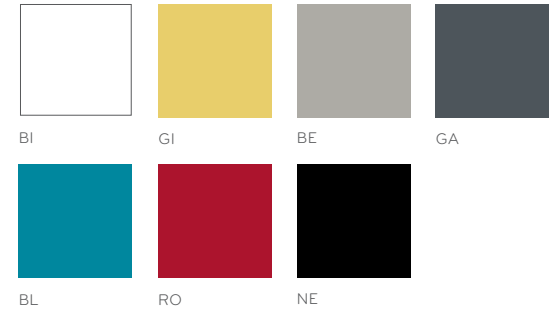

675



670



670



675



675





Art. 678

Lo sgabello in polipropilene Volt, dai volumi puri e linee definite, mantiene invariata la cura dei dettagli e la tecnologia produttiva che identificano l'omonima collezione. Le dimensioni contenute, abbinate a forme ergonomiche, assicurano funzionalità e comfort. Il poggiatesta che continua su tre lati avvolge le gambe come una fascia e aumenta la resistenza dello sgabello, garantendone l'impilabilità.

Volt polypropylene barstool, with its pure volume and its well defined lines is the result of excellent selection of the best technologies and researches in plastic materials. The compact size and ergonomic shape ensure functionality and comfort. The footrest on three sides, like a bend, grants the stackability.

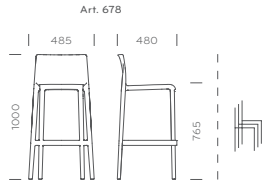

colori / colours:

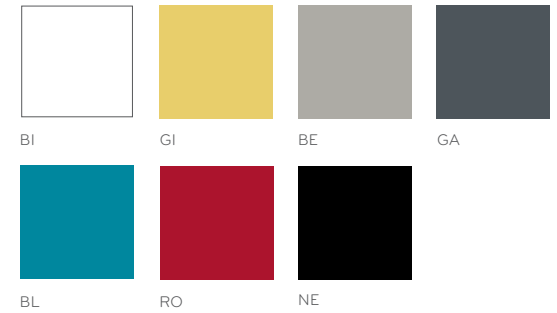

Art. 671 - 676
Sedia e poltrona Volt sono disponibili anche nelle versioni con parte frontale imbottita rivestita in tessuto o finta pelle.
Chair and armchair Volt with padded panel on the frontal side, covered with fabric or simil leather.

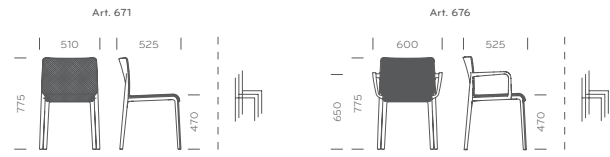

Categorie rivestimenti disponibili: C01+C07, C74+C79, C90+C95
Covering categories available: C01+C07, C74+C79, C90+C95



671



676



671

Tweet

Design Marc Sadler

Art. 890 - 895

Tweet nasce dalla volontà di creare un elemento di arredo razionale e adatto ad essere inserito anche negli ambienti più connotati, rispettandone lo stile. La scocca in polipropilene stampato o bi-iniezione ha finitura opaca antigraffio per la parte frontale, finitura lucida per il retro. Disponibile nella versione monocromatica o bicromatica con parte frontale sempre bianca. Struttura in acciaio Ø14mm cromato, cromato nero oppure verniciato.

Tweet was conceived from the desire to create a rational piece of furniture suitable to be placed even in the most characteristic spaces, respecting their style. Bi-injected moulding polypropylene shell, matt and scratch resistant on the frontal part, glossy finish on the back part. One-colour or bicolour version with white front part available. Steel tube frame Ø14mm, black chromed, chromed or powder coated finish.

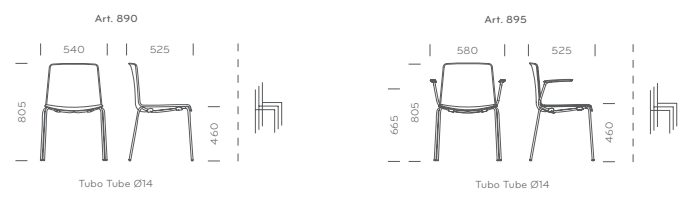

colori / colours:

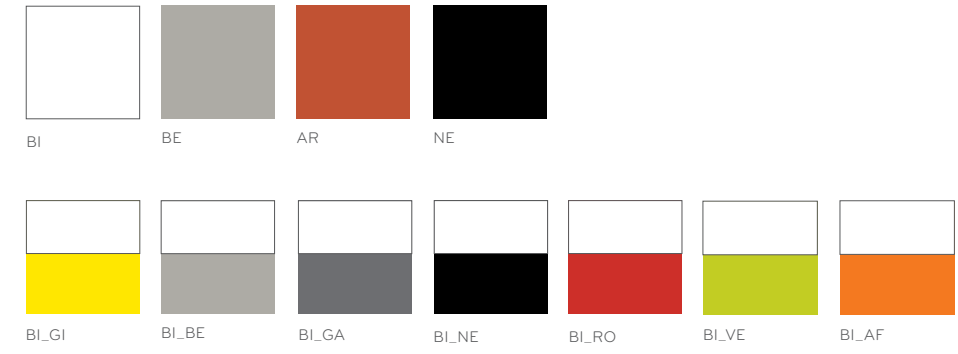

Art. 895
La poltrona Tweet ha scocca in polipropilene stampato a bi-iniezione e braccioli in tinta col colore della scocca esterna.
Tweet armchair has bi-injected moulding polypropylene shell and armrests in the same colour of the back part of the shell.

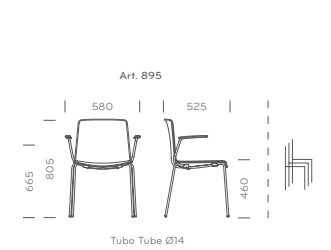

895

Art. 892 - 896
Lo sgabello Tweet, disponibile in due altezze, ha telaio in acciaio Ø14 mm, verniciato, cromato o cromato nero.
Tweet bar stool, two heights, has Ø14 mm steel tube frame in powder coated, chromed or black chromed finish.

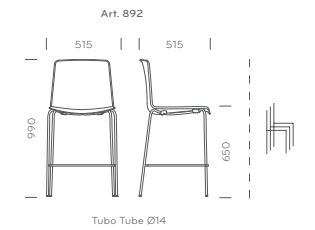
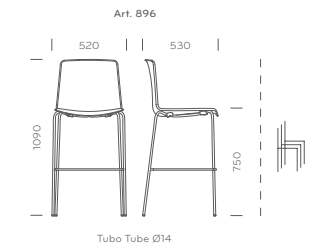

896

16 Tweet

Art. 890

Tweet versione bicolore ha la parte frontale della scocca sempre bianca, finitura opaca antigraffio, e parte posteriore colorata, finitura lucida.
Tweet bicolour version has white matt and scratch resistant frontal shell and colored back part, glossy finish.



Art. 895 - 890
Tweet con scocca monocromatica disponibile nei colori bianco, beige, arancio e nero.
Teloio verniciato, cromato o cromato nero.
Tweet one-colour shell is available in white, beige, orange or black finish. Powder coated, chromed or black chromed frame.

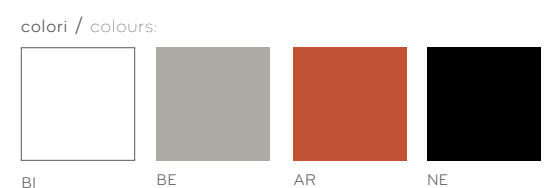
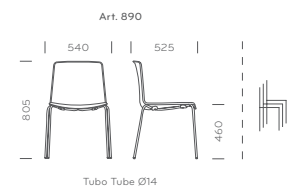
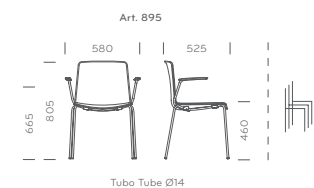

895



890



Art. 899 - 897 - 898
Tweet sedia e poltrona con telaio a slitta in tondino d'acciaio Ø 11 mm sono impilabili.
Disponibile anche lo sgabello altezza 750 mm.
Tweet chair and armchair with steel rod frame Ø 11 mm are stackable. Bar stool version
height 750 mm also available.

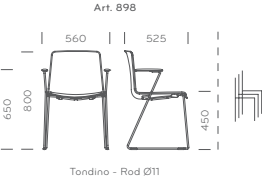
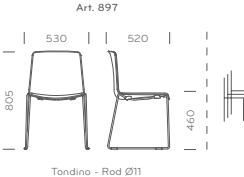
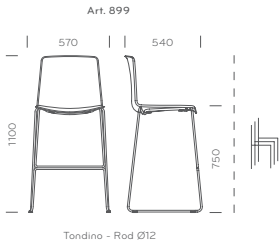

899



897



898

Art. 891
Tweet con base centrale girevole in acciaio verniciato nero munita di ruote. Alzata a gas.
Tweet with die-casted black powdered steel central four spokes base with castors. Gas lift device.

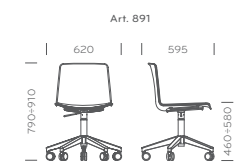

colori / colours:



BL_NE



891



890

Design Marc Sadler

 red dot design award
 winner 2013

Art. 725

Noa unisce l'eleganza delle sue perfette proporzioni al comfort della seduta, il tutto grazie all'innovativa tecnica costruttiva. La seduta è imbottita ed è contenuta in una scocca in policarbonato la cui superficie esterna è lucida.

Noa combines the elegance of its perfect proportions to the comfort of the seat, all thanks to the innovative construction technique. The seat is upholstered and contained in a polycarbonate shell with a glossy outer surface.

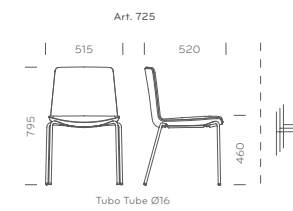

colori scocca / shell colours:



Categorie rivestimenti disponibili: da C50 a C57, G, H
 Covering categories available: from C50 to C57, G, H





Art. 725

Noa è impilabile. Le gambe possono essere in acciaio cromato oppure verniciato in tinta con la scocca in policarbonato nero o bianco.
 Noa is stackable. The legs are chromed or powder coated in the same colour of the polycarbonate shell, black or white.





Art. 727 - 727/2

La sedia Noa è disponibile anche nella versione con base a 4 razze in pressofusione di alluminio, munita di ruote oppure con piedini fissi. La gamma dei rivestimenti della seduta in tessuto o ecopelle, in combinazione con i colori della scocca offre una vasta scelta di possibili personalizzazioni e soluzioni arredative sia contract che office e residential.
 Noa chair 4 feet die-casted aluminium base on castors or with fixed feet also available. The upholstery range of fabric or eco-leather for the seat in combination with the colours of the shell offers a wide range of possible customizations and solutions for contract, office and residential furnishings.

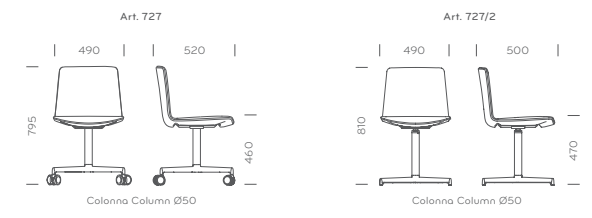

Categorie rivestimenti disponibili: da C50 a C57, G, H
 Covering categories available: from C50 to C57, G, H



727

Art. 726 - 728 - 728/2

Design minimale e studiato nei particolari per Noa versione poltrona. Il bracciolo ha finitura lucida ed è in tinta con la scocca bianco o nero. Noa poltrona è impilabile. Disponibile anche nella versione con base a 4 razze, con e senza ruote, in pressofusione di alluminio verniciato bianco e nero oppure finitura lucida.
Minimal and detailed design for Noa armchair version. The armrest has the same glossy finish of the white or black shell. Noa armchair is stackable. 4 feet die-casted aluminium base with or without castors also available, white and black powder coated or polished finish.

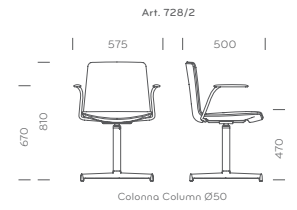
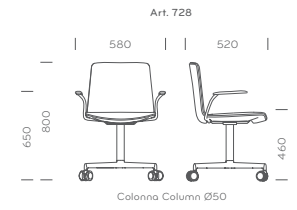

Categorie rivestimenti disponibili: da C50 a C57, G, H
Covering categories available: from C50 to C57, G, H

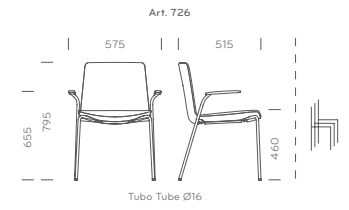

Categorie rivestimenti disponibili: da C50 a C57, G, H
Covering categories available: from C50 to C57, G, H



728



726



Snow



Design Odo Fioravanti



1° Premio Young&Design 2008

Art. 300

Sedia Snow in polipropilene, leggera e resistente ai raggi UV è l'ideale per l'esterno. Impilabile, è disponibile nei colori bianco, beige, sabbia, arancio, verde, rosso, blu e nero.

Snow chair, polypropylene one moulded piece, lightweight and UV beams resistant is ideal for outdoor use. Stackable, it is available in white, beige, sand, orange, green, red, blue and black colours.

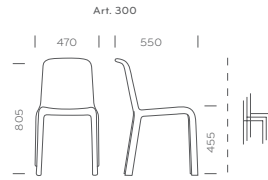

colori / colours:

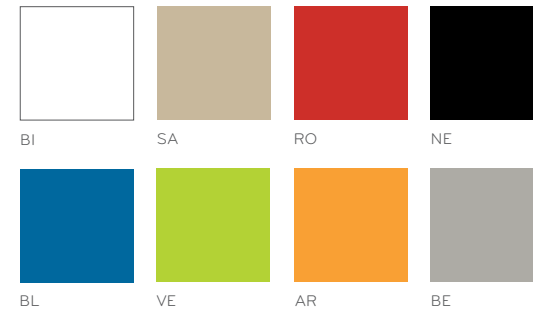



Art. 300

Grazie al suo design minimale e alla sua pulizia formale, Snow è funzionale per arredare i grandi spazi della collettività.
Thanks to its minimal design and clear lines, Snow is functional to furnish community areas.





Art. 300

Snow ha particolare foro di scarico sul sedile per facilitare il deflusso dell'acqua. Caratterizzato dai profili ovali che le donano resistenza e diventano naturali maniglie per afferrarla. Snow is characterized by rounded profiles that make it strong and handy. Peculiar is the water outflow hole on the seat part.







Art. 301

Snow table vuole comunicare le stesse sensazioni di dinamismo e velocità già proprie della Snow chair. Tavolo con ripiano in polipropilene stampato in gas air moulding e gambe in estruso di alluminio. Ideale per indoor e outdoor è disponibile nei colori bianco, beige e sabbia. Impilabile fino a 3 pezzi.

Snow table project took life from the idea to match a table to Snow chair, maintaining the same dynamism and speed in three-dimensional shape. Table with extruded aluminium legs and gas air moulding polypropylene top. Ideal for indoor and outdoor use, Snow table is available in white, beige and sand colours. Stackable up to 3 pcs.

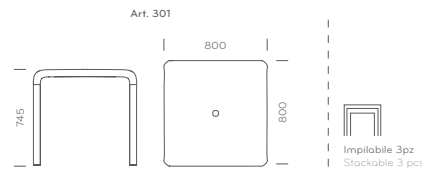

colori / colours:





Art. 303

L'estetica innovativa e organica di Snow ha ispirato un adattamento naturale al mondo dei più piccoli senza perdere la forza di una forma inconfondibile. Snow Junior è in polipropilene caricato con fibre di vetro e stampato ad iniezione con gas moulding.

The innovative and organic design of Snow chair has been a perfect inspiration of the world of kids without losing the strength of an unmistakable shape. Snow Junior is made of polypropylene reinforced by glass fibers, injected with moulding technology.

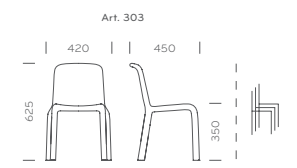

colori / colours:

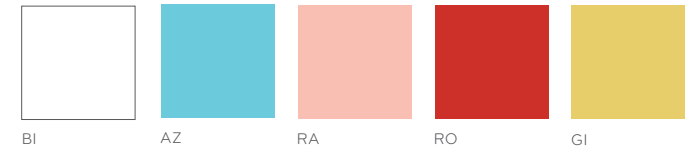

300



303



303





Design Jorge Pensi Design Studio



reddot design award
winner 2013

Art. 315

Ara è una poltroncina stampata in polipropilene caricato fibra di vetro, 100% riciclabile. Impilabile, grazie alla forma affusolata delle gambe appare leggero ed elegante pur essendo robusta e indeformabile.

Ara polypropylene moulded armchair reinforced with fiberglass, 100% recyclable. Stackable, thanks to the tapered shape of the legs it's light and elegant, although resistant and non-deformable.

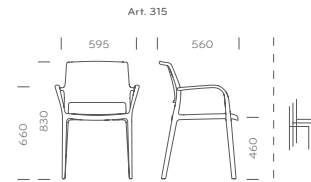

colori / colours:

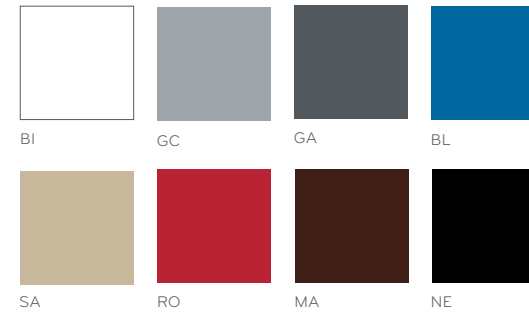

La struttura dello schienale forma, nella parte alta, una grande maniglia che facilita il sollevamento e lo spostamento e conferisce ad Ara un distinto carattere.
The upper part of back structure forms a big handle for an easy lifting and moving, giving it a distinct character.





Art. 310.3

Il cuscino per utilizzo indoor aumenta il comfort della seduta senza rinunciare alla funzionalità. È termoformato ed applicabile alla seduta di sedia e poltrona grazie ad alcuni inserti in velcro. Fodera idrorepellente e antimacchia.
The indoor cushion makes the seat more comfortable without renouncing at functionality. It is thermoformed and can be applied to the seat of chair and armchair thanks to velcro inserts. Waterproof and stain-resistant cover.

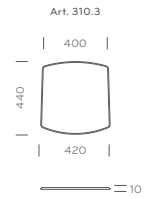



Art. 315
Ara è l'ideale per vivere sia gli spazi indoor che outdoor.
Ara is suitable for both indoor and outdoor environments.





Art. 310

La maniglia segno d'identità contraddistingue Ara anche nella versione sedia. Caratterizzata dalla stessa eleganza e pulizia formale della poltrona, Ara è disponibile nei colori bianco, sabbia, grigio chiaro, grigio antracite, blu, marrone, rosso e nero.

The handle of the back is a sign of identity also for Ara chair version. Characterized by the same elegance and clear lines of the armchair, Ara is available in white, beige, clear grey, anthracite grey, blue, brown, red and black colours.

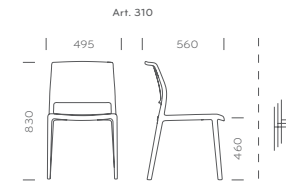

Babila

Design Odo Fioravanti

Art. 2730
 La scocca della sedia Babila in tecnopolimero richiama il disegno della versione in legno ma sfrutta l'elasticità e la tridimensionalità del materiale plastico per offrire il massimo comfort in una veste più smart. Gambe in tubo d'acciaio Ø16 mm. Impilabile.
 The technopolymer shell of Babila chair recalls the wooden version but takes full advantage of elasticity and three-dimensionality of the plastic material, in order to offer the greatest comfort in a new smarter look. Steel tube legs Ø16 mm. Stackable.

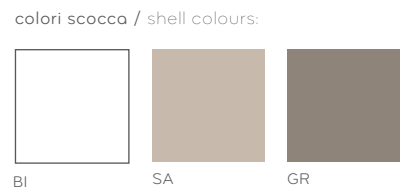
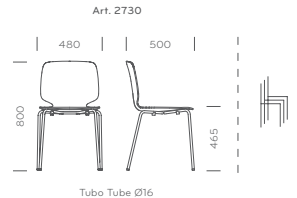

Art. 2740
Sedia Babila con telaio a slitta in tondino Ø 10 mm. Impilabile. Una delicata modanatura caratterizza la parte posteriore dello schienale.
Babila chair with sled steel rod frame Ø 10 mm. Stackable. A delicate moulding characterizes the back.

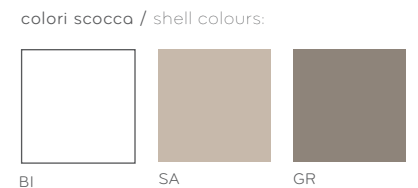
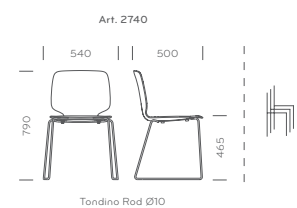



Art. 2700 - 2750

Babila è una sedia che si muove con grande agilità tra tradizione e innovazione. La scocca è realizzata in multistrato a spessore variabile e le gambe sono in massello di frassino. Il risultato è una seduta aerea e confortevole, che utilizza il legno solo dove serve. Disponibile la versione con scocca in tecnopolimero abbinata a gambe in frassino.

Babila is a chair able to move along tradition and innovation with great agility. Plywood shell in variable thickness and solid ash legs. The result is an airy and comfortable sitting with a careful and accurate use of wood. Version with technopolymer shell and ash wooden legs also available.

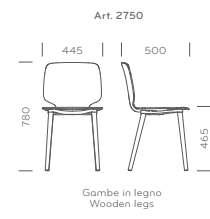

colori scocca / shell colours:



finiture / finishes:



2750



2700



Koi-Booki



Design Claudio Dondoli and Marco Pocci

Art. 370

Koi-Booki è una sedia in polipropilene 100% riciclabile, stampata ad iniezione, con gambe in estruso di alluminio e telaio in pressofusione di alluminio. Ideale per outdoor, è disponibile anche in versione ignifuga.
Koi-Booki polypropylene chair, 100% recyclable, injected polypropylene shell, legs of extruded aluminium and frame made of die-casted aluminium. Ideal for outdoor use, fire-retardant version is also available.

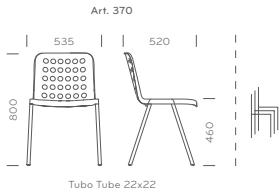

Koi-Booki



Art. 370

Impilabile in verticale fino a 20 pezzi, Koi-Booki è leggera e resistente. La scocca è disponibile nei colori: bianco, sabbia, arancio, nero e blu abbinata a telaio verniciato in tinta.
Vertically stackable up to 20 pcs, Koi-Booki is lightweight and resistant. The shell is available in white, beige, orange, black or blue with matching powder coated frame.

colori / colours:





Art. 370/G

Koi-Booki può essere dotata di gancio di connessione in alluminio anodizzato per comporre file di sedute, personalizzabile con applicazione di adesivi numerati. Disponibile anche il cuscino accessorio in tessuto termoformato per utilizzo indoor (Art. 370.3).
 Koi-Booki can be equipped with an anodized aluminium linking device to form rows of seat, customizable through application of adhesive labels. Thermoformed fabric cushion for indoor use also available (Art. 370.3).

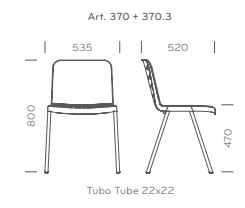
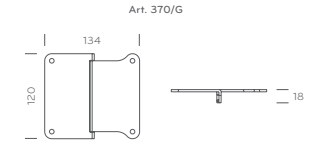



Design Claudio Dondoli and Marco Poggi

Art. 870

La sua forma razionale rende Joi estremamente funzionale. Seduta e schienale sono in monoscocca stampata in polipropilene. Le gambe sono in estruso di alluminio anodizzato satinato a sezione quadrata con spigoli arrotondati. Joi è impilabile.

Joi is extremely functional thanks to its rational shape. One piece moulded seat and back polypropylene chair. The legs are made in square satin anodized extruded aluminium with round edges. Joi is stackable.

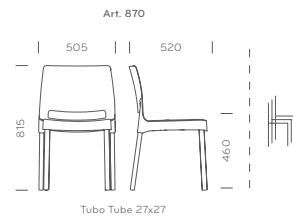

colori scocca:
shell colours:

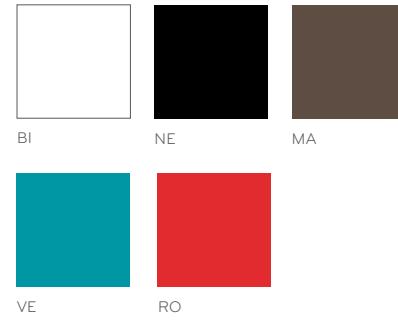



Art. 870

Leggera e maneggevole, Joi è l'ideale per l'esterno.
Lightweight and easy to move, Joi is ideal for outdoor use.



Joi 67





Art. 870 - 870/G

Joi può essere dotata di gancio di connessione in nylon per comporre file di sedie per sale riunioni, anfiteatri, aule. Disponibile anche nella versione in polipropilene ignifugo. Joi can be equipped with a nylon linking device to form rows of seats for meeting rooms, theaters, classrooms. Fire-retardant chair version available.



870 + 870/G



Art. 700

Leggera e impilabile, la sedia Mya ha seduta e schienale in polipropilene e telaio in un unico pezzo in pressofusione di alluminio con gambe affusolate. Impilabile.
Lightweight and stackable, Mya chair has polypropylene seat and back and die-casted aluminium frame with tapered legs. Stackable.

Disponibile la versione rivestita in vera o finta pelle sul catalogo TouchSoft.
Upholstered version covered with simil-leather or mid grain leather is available in our TouchSoft catalogue.

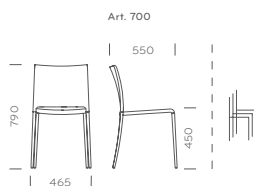

Art. 700 - Sedia Mya con tavolo Inox regolabile in altezza (Art. 4402H).
Mya Chair and Inox table with gas lift device (Art. 4402H).



Art. 700

Mya è disponibile nei colori nero, bianco, rosso, sabbia e grigio antracite. Gambe verniciate in tinta con la scocca oppure in alluminio lucidato o satinato.
Colours available for Mya chair: black, white, red, beige and anthracite gray. Powder coated aluminium legs in the same colour of seat and back or in polished or brushed aluminium.

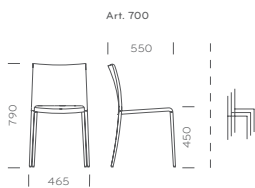

colori / colours:



BI SA GA RO NE



Art. PLO_360X120 - Tavolo riunioni Plano con ripiano ovale abbinato a basi in acciaio inox quadrate. Versione con canalina elettrificabile.
Plano meeting table, oval top combined to square stainless steel bases. Desk cable management.

Art. 705/2
Poltroncina Mya con braccioli e gambe in pressofusione di alluminio verniciate in tinta nello stesso colore di sedile e schienale oppure nella versione in alluminio satinato.
Mya armchair with die-casted aluminium armrests and frame, powder coated in the same colours of the seat and back on in brushed aluminium.

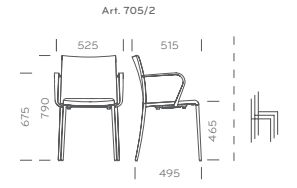

colori / colours:

BI	SA	GA	RO	NE





Art. 701 - 706/2

Mya Tecnica è la versione con seduta in polipropilene e schienale in textilene, nelle varianti sedia e poltrona. Gambe in pressofusione di alluminio verniciate per esterni. Impilabile.
Mya Tecnica chair and armchair with polypropylene seat and mesh textilene back. Die-casted powder coated aluminium legs suitable for outdoor use. Stackable.

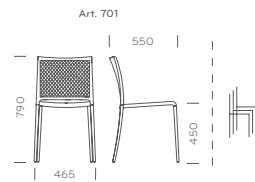

colori / colours:

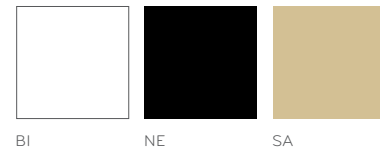

colori textilene / textilene colours:

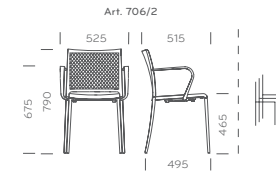
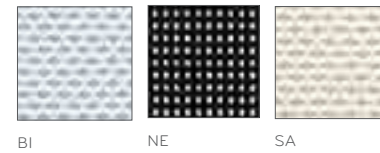

701





Art. 705/2
Poltrona Mya versione full colour bianco,
verniciata per esterni.
White full colour Mya armchair version,
powder coated frame for outdoor use.

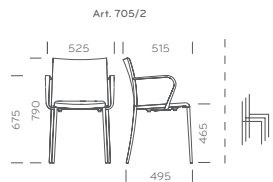

Tavolo Matrix (Art. TMD_200x86) versione fissa con struttura in estruso di alluminio anodizzato e ripiano a doghe Compact Full Colour bianco.
Fixed Matrix table version (Art. TMD_200x86) with extruded anodized aluminium frame and leaves in solid laminate white Compact Full Colour.

Art. CG

Gancio di collegamento ad incastro sotto il sedile per sedie Mya realizzato in fondino cromato Ø mm 6.
 La sedia con gancio rimane impilabile.
 Agganciate, le sedute distano mm 125 l'una dall'altra.
 Mya linking device, Ø 6 mm chromed steel rod. It keeps the chairs stackable.
 Linked, seats keep a distance of 125 mm one each other.



Art. 1391.100

Carrello per sedie, in metallo verniciato alluminio; per movimentare sino a 15 sedie.
 Chair trolley in silver powder-coated finish to move up to fifteen stacked chairs.





Art. 411

Grace ha la scocca realizzata in polipropilene, materiale sottile, robusto ed antistatico. Disponibile con telaio in fondino d'acciaio cromato o verniciato arancio, nero o bianco in tinta con la scocca.
 Grace armchair, shell made of polypropylene, thin, strong and antistatic material. Available with chromed steel rod frame or orange, black or white powder coated steel rod frame in the same colour of the shell.

Disponibile la versione imbottita sul catalogo TouchSoft.
 Upholstered version in our TouchSoft catalogue.

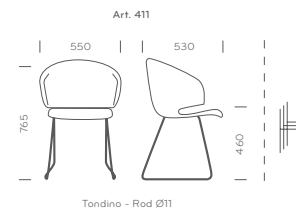

colori scocca:
 shell colours:

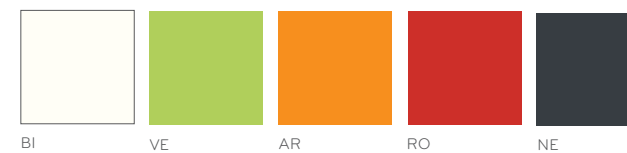

Design Claudio Dondoli and Marco Poggi



Art. 4830
 Tavolo Dream
 verniciato bianco e
 ripiano in stratificato
 Full Colour bianco.
 Dream table and white
 Compact Full Colour
 solid laminate top.



Art. 410- Poltroncina Grace e tavolo Inox (Art. 4421/LU) con ripiano impiallacciato rovere tinto wengé.
Grace armchair and Inox table (Art. 4421/LU) with oak veneered top stained wenge color.



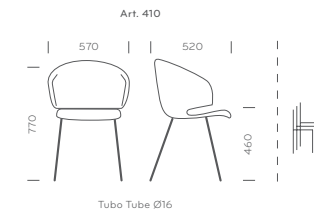

Art. 410

Poltroncina Grace nella versione con gambe in tubo d'acciaio cromato, disponibili anche verniciate alluminio o in acciaio inox per esterno. Impilabile.

Grace armchair with chromed steel tube legs. Available also with silver powder coated frame or with stainless steel frame for outdoor. Stackable.

Disponibile la versione imbottita sul catalogo TouchSoft.
 Upholstered version available in our TouchSoft catalogue.





Art. 460

Enjoy è la pieghevole universale, leggera e compatta. Realizzata interamente in polipropilene 100% riciclabile, senza interferenza di viti o altri materiali, ha particolare texture della superficie ed è disponibile nei colori: bianco, rosso e nero.
 Enjoy, the universal folding chair, lightweight and compact. Completely made in 100% recyclable polypropylene, without metal screws, fasteners or other, it has textured surface in white, red or black colour.

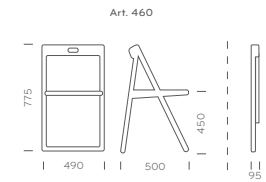

Colori disponibili
 Available colours

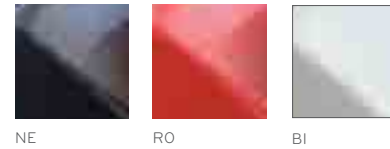

NE RO BI



Enjoy

Design Claudio Dondoli and Marco Poggi



Art. 460

Resistente ai raggi UV, Enjoy può essere utilizzata anche in spazi all'aperto. Chiusa può essere movimentata grazie ad un carrello dedicato che contiene fino a 40 sedie (Art. 465-466).
Resistant to UV beams, Enjoy is suitable also for outdoor use. Trolley available to move up to 40 chairs (Art. 465-466).



92 Blitz

Design Claudio Dondoli and Marco Poggi

Art. 640

La forma rassicurante e la struttura essenziale rendono Blitz facile da inserire in qualsiasi ambiente. Impilabile, è realizzata interamente in policarbonato trasparente o full colour. Disponibile a richiesta anche nella versione ignifuga. Its reassuring shape and the essential structure make Blitz easy to fit into any environment. Stackable, Blitz is made completely in transparent or full colour polycarbonate. Fire-retardant version also available.

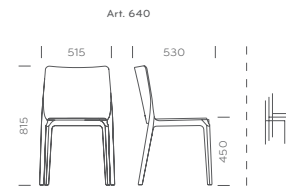

colori / colours:

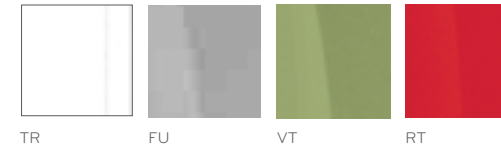

Lo schienale ha finitura lucida, la seduta antigraffio è foto-incisa. The backrest has a glossy finish, the seat has a slight rough anti-scratch finish.





Art. 640.3
La seduta foto-incisa può ricevere un'imbottitura leggermente incassata rivestita in tessuto o finta pelle.
The seat has a slight rough finish and can have a recessed padding, covered with various fabrics and eco-leather.

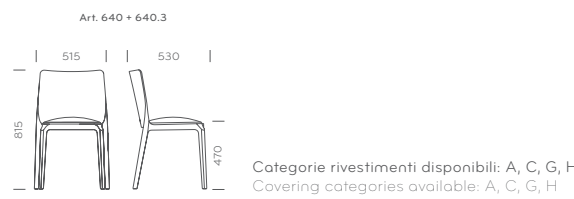

640 + 640.3



640 + 640.3





Art. 640

Elegante e discreta nella versione in policarbonato full colour, Blitz è disponibile nei colori bianco, nero, sabbia e grigio.
Elegant and discrete in full colour polycarbonate version, Blitz is available in white, black, beige and grey colours.

colori / colours:

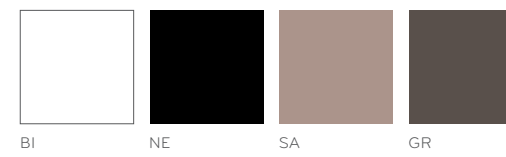



Art. TMF_86X86 - Tavolo Matrix con vetro laccato nero.
Matrix table with black lacquered glass top.

Art. 401 - 405

Day Dream con scocca in policarbonato full colour e telaio in tubo o tondino d'acciaio verniciato in tinta.
Day Dream chair, full colour polycarbonate shell and powder coated frame in the same colour.

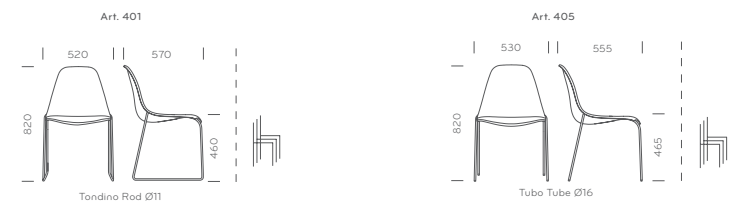

colori scocca / shell colours:

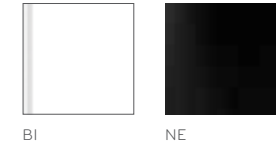

Day Dream 103

Design Claudio Dondoli and Marco Pocci

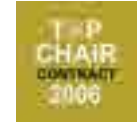

405



401



Art. 405
Day Dream versione con telaio in tubo d'acciaio Ø mm 16, disponibile cromato, cromato opaco, verniciato alluminio per esterni, verniciato bianco o nero. Con scocca in policarbonato trasparente colorata o full colour. Impilabile.
Day Dream chair, Ø 16 mm round tube frame version, available in chromed, matt chromed, aluminium powder coated for outdoor use, black or white powder coated. Shell in transparent or full colour polycarbonate. Stackable.

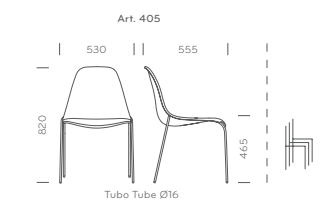

Art. 4402/AC - Tavoli modello Inox con ripiano in acciaio inox.
Inox tables with stainless steel top.



Art. TE_178x90
 Tavolo Exteso in faggio
 laccato bianco goffrato.
 Allungabile
 Exteso table in white matt
 laquered beech wood.
 Extensible.

Art. 401

Day Dream in policarbonato trasparente neutro o colorato rosso e blu. Telaio in
 fondino d'acciaio cromato Ø 11 mm fissato alla scocca mediante incastro. Impilabile.
 Day Dream chair, transparent polycarbonate shell available in clear, red and blue
 colour clipped to the Ø 11 mm chromed steel rod frame. Stackable.

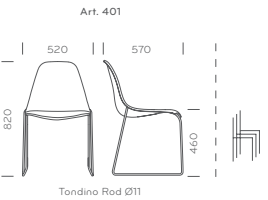

colori scocca:
 shell colours:

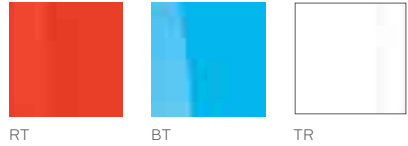

108 Miss_You

Design Marco Piva

Art. 610

Miss_You è in policarbonato, materiale atossico, resistente agli urti ed infrangibile. Ergonomica grazie alle forme organiche e sinuose è leggera e maneggevole, dall'aspetto quasi immateriale. L'innovativo processo di stampaggio ha permesso una diversa colorazione del profilo rispetto alla seduta e schienale.
Miss_You chair in polycarbonate, a non-toxic, shock resistant and unbreakable material. Light and comfortable. Its profile and seat can be in different colours, thanks to its innovative and particular moulding system.

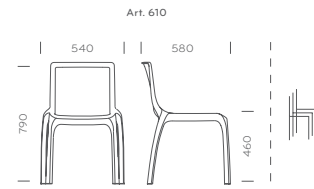

610/TR_BI



610/BL_TR



Tavoli Krystal con top in vetro laccato nero.
Krystal bases with black lacquered glass top.

110 Miss_You

Art. 610
Miss_You è disponibile con seduta bianca e profilo trasparente oppure con seduta trasparente e profilo bianco, nero, fumè o ambro.
Miss_You chair is available with white seat and transparent profile or with transparent seat and profile in white, black, fumè or amber colour.

colori / colours:

		
NE_TR	BL_TR	TR_BI
		
FU_TR	AM_TR	





Design Claudio Dondoli and Marco Poggi

Art. 660

La poltrona Pasha è il connubio tra tradizione e innovazione. Completamente in policarbonato, materiale dalle rinomate qualità prestazionali.
Pasha lounge armchair is a perfect synthesis of tradition and innovation. In injection moulded polycarbonate, material of distinguishing quality performance.

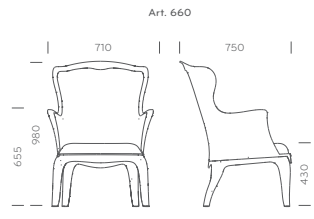

colori / colours:



FU

TR



BI

NE

Solo per utilizzo interno
For indoor use only





Art. 660

Pasha è l'ideale per connotare con un'immagine di prestigio le aree lounge degli hotel così come raffinate sale ristorante.
Pasha confers a prestigious character to different locations such as hotel lounges and stylish restaurants.







Art. 660
La poltrona Pasha in policarbonato trasparente, fumè e bianco si inserisce anche negli ambienti outdoor.
Pasha armchair in transparent, fumè or white polycarbonate is suitable also for outdoor environments.



Art. 660.8

La pratica vestina in cotone rende Pasha ideale per le situazioni catering&banqueting.
The practical cotton covering makes Pasha ideal for catering&banqueting solutions.

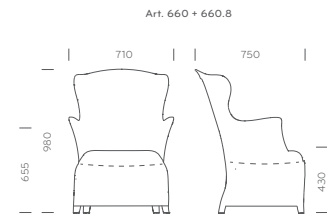

Categorie rivestimenti disponibili: da A10 a A14
Covering categories available: from A10 to A14



660 + 660.8

Art. 660.3

La comoda seduta caratterizzata da ampie proporzioni è resa ancora più confortevole dal cuscino imbottito rivestito in tessuto che conferisce un carattere personale all'ambiente.
The seat offers great comfort and becomes even more attractive thanks to an upholstered cushion covered by cool fabrics. This version gives brightness and character to the interiors.

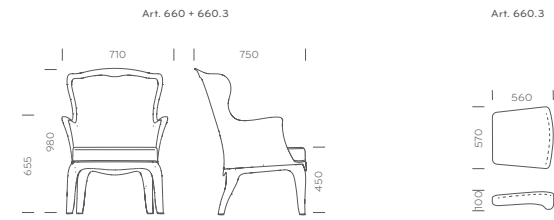

Categorie rivestimenti disponibili: da H40 a H53, G90-G91, da C70 a C72
Covering categories available: from H40 to H53, G90-G91, from C70 to C72



660 + 660.3



Art. 661 - 662

Pasha pouf, tavolino lounge o seduta. Accostabile alla poltrona o proposto come complemento d'arredo indipendente, è comodo e versatile nell'utilizzo. Proposto nelle tonalità del bianco e nero lucido o nelle versioni trasparente e fumè. Accessoriabile con un pratico vassoio realizzato in resina melaminica ad alta resistenza conforme all'uso alimentare, di facile manutenzione e movimentazione grazie alle maniglie laterali, disponibile in bianco o nero full colour.

Pasha ottoman, lounge table or low seat. Comfortable and versatile, it can be combined with the armchair or separately used as a fancy complement. Available in white and black glossy finish or in transparent and smoky grey version. Available a practical tray made of high pressure melamine suitable for food use, easy to maintain and to move thanks to the lateral handles, white or black full colour version available.

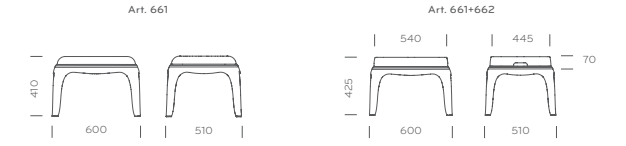

colori / colours:



FU TR BI NE

Solo per utilizzo interno
For indoor use only





124 Queen

Design Claudio Dondoli and Marco Poggi

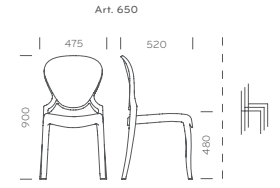
Art. 650
Sedia Queen, leggera in policarbonato nei colori trasparenti o full colour bianco, sabbia e nero. Disponibile il carrello, per movimentare sino a 10 sedie.
Queen chair, one moulded piece in polycarbonate, lightweight, in transparent colours or white, beige and black full colours. Chair trolley available to move up to 10 chairs together.



colori / colours:

		
BI	SA	NE

Solo per utilizzo interno
For indoor use only





Queen 127





Art. 650.3

Queen è accessoriabile con cuscino sfoderabile, rivestito in tessuto o finta pelle, che si fissa al sedile mediante semplice applicazione ad incastro.
 Upholstered cushion available, fabric or simil-leather covering, easily fixable to the seat.

Art. 650.3



Categorie rivestimenti disponibili: G01+G10, G90+G91, H40+H53
 Covering categories available: G01+G10, G90+G91, H40+H53



650 + 650.3



650



Art. 650

Queen è disponibile in policarbonato trasparente neutro, fumè, ombra o viola.
Queen is available in clear, fumè, amber or violet transparent polycarbonate colours.

colori / colours:

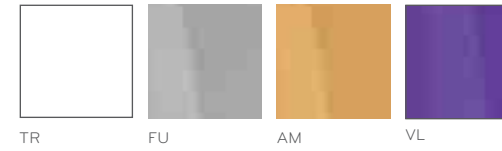

TR

FU

AM

VL





Art. 620 - Poltroncina Gossip trasparente e tavoli Inox (Art. 4441/LU) con ripiani impiallaccati rovere tinto wengé.
Transparent Gossip armchair and Inox table (Art. 4441/LU) with oak veneered top stained wenge color.

Art. 620

Gossip è realizzata in policarbonato trasparente neutro, fumè, ambra oppure nella versione full colour nero o bianco. Impilabile.
Gossip armchair in transparent polycarbonate (clear, smoke grey, amber colours) or full colour polycarbonate (white or black). Stackable.

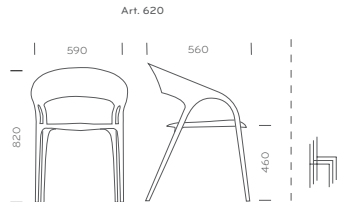

colori / colours:



Solo per utilizzo interno
For indoor use only





Art. 4402/AC - Tavolo Inox con top impiallacciato rovere tinto wengé.
Inox table with oak veneered top stained wenge.

Gossip in policarbonato trasparente color ombra, elegante e raffinato.
Gossip armchair in amber transparent polycarbonate, stylish and refined.





Tavolo modello Inox (Art. 4411/LU) con ripiano in vetro laccato nero.
Inox table (Art. 4411/LU) with black lacquered glass top.

Art. 620

Gossip versione in policarbonato full colour nero. Disponibile full colour bianco. Impilabile.
Gossip armchair, full colour black polycarbonate. White full colour version available. Stackable.



140 Gossip

Art. 620 - Gossip in policarbonato full colour bianco e tavolo modello Bold (Art. 4750) verniciato bianco per esterni. Ripiano in stratificato Compact Full Colour.
Gossip armchair, full colour white polycarbonate version and Bold table (Art. 4750) white powder coated for outdoor use. Compact Full Colour solid laminate top.



142 Gliss Policarbonato

Design Claudio Dondoli and Marco Poggi



Art. 4421/AC - Tavolo Inox e top in laminato wengé.
Inox table and wenge laminated top.





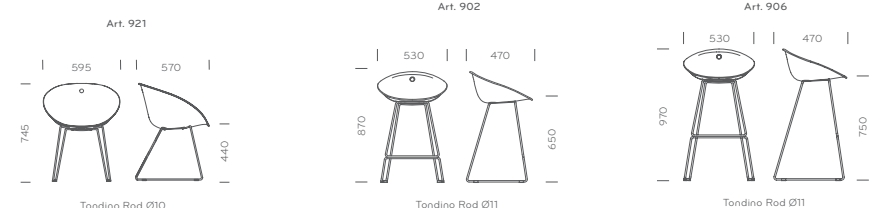

Art. 921

La poltroncina Gliss con scocca in policarbonato è disponibile nei colori trasparenti: rosso, arancio, verde, trasparente o fumé. Versione full colour nero.
Gliss armchair with polycarbonate shell is available in transparent colours (red, orange, green, clear or smoke grey) or in black full colour version.

Disponibile la versione sgabello nelle due altezze mm 650 o mm 750 sul catalogo keepingHIGH.
Gliss stool version 650 mm or 750 mm height available. See our keepingHIGH catalogue.



colori scocca / shell colours:

		
RT	AT	TR
		
VT	FU	NE



144 Gliss Policarbonato

Art. 921

Poltroncina Gliss con scocca in policarbonato trasparente o full colour. Telaio in tondino d'acciaio cromato Ø10mm.
Gliss armchair, transparent or full colour polycarbonate shell. Chromed steel rod frame Ø10mm.

Disponibile la versione rivestita in tessuto, finto pelle o cuoio sul catalogo TouchSoft.
Version covered with fabric, simil-leather or genuine leather available in our TouchSoft catalogue.



146 Gliss Policarbonato

Art. 968
Gliss con scocca in policarbonato trasparente su ruote. Disponibile nei colori trasparenti verde, rosso, arancio, trasparente e fumé. Telaio in tubo d'acciaio cromato Ø mm 16.
Gliss armchair, transparent polycarbonate shell and frame with castors. Available in transparent colours: green, red, orange, clear or smoke grey Ø 16 mm chromed steel tube frame.

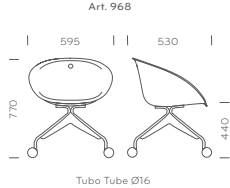

148 Gliss Tecnopolimero

Art. 920
 Poltroncina Gliss con scocca in tecnopolimero bianco o sabbia, materiale resistente e di facile manutenzione.
 Gliss armchair, white or beige technopolymer shell, strong and east to maintain.

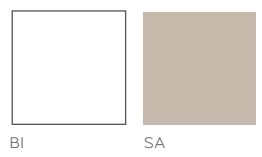

Sedia Gliss (Art. 920) e tavolo Dream bianco (Art. 4830) con top in stratificato Compact Full Colour bianco.
 Gliss chair (Art. 920) and white Dream table (Art. 4830) with white Compact Full Colour solid laminate top.

Art. 921
 Gliss con scocca in policarbonato full colour nero su telaio in tondino d'acciaio cromato.
 Gliss chair, black full colour polycarbonate shell and chromed steel rod frame.

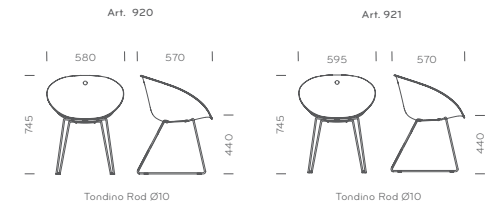

Policarbonato Gliss 149



921

150 Gliss Tecnopolimero

Art. 900 - 960
 Poltroncina Gliss in tecnopolimero bianco o sabbia con gambe in tubo d'acciaio Ø mm 16 (Art. 900) o con base girevole su ruote e alzato regolabile a gas, in alluminio lucidato (Art. 960).
 Gliss armchair with white or beige technopolymer shell, with Ø 16 mm steel tube legs (Art. 900) or with swivel base on wheels and gas lift device, in polished aluminium (Art. 960).

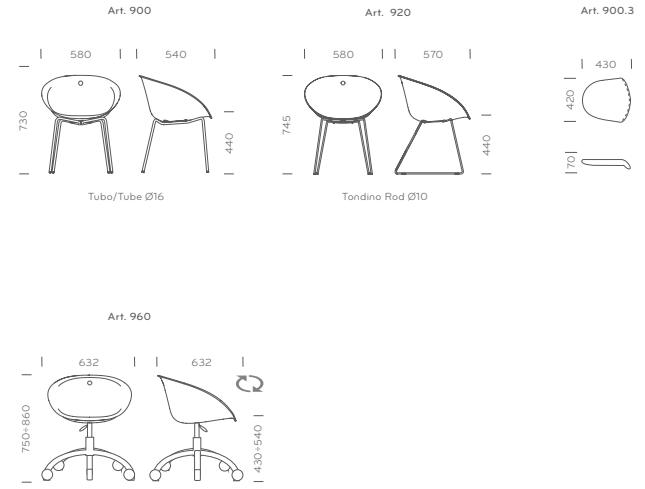

900



960

Art. 920 + 900.3
 Gliss con cuscino sfoderabile in tessuto o finta pelle disponibile a scelta tra una vasta gamma.
 Gliss with removable covering cushion, available in a wide range of fabrics or simil-leather.



920

152 Gliss Policarbonato

Art. 951 - 952
 Gliss girevole, regolabile in altezza con alzato a gas. Base in acciaio inox lucidato, colonna in acciaio cromato. Scocca in policarbonato trasparente colorato (Art. 951) o nero full colour (Art. 952).
 Gliss chair, swivel version with gas lift device adjustable in height. Polished stainless steel base, chromed steel column. Transparent coloured polycarbonate shell (Art. 951) or black full colour version (Art. 952).

Disponibile la versione sgabello sul catalogo KeepingHigh.
 Stool version in our KeepingHigh catalogue.

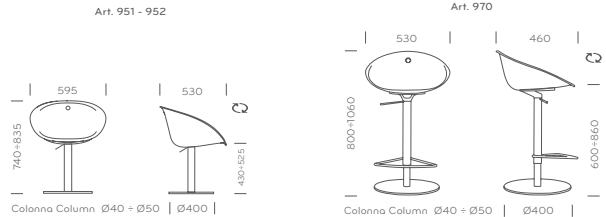

951



952



940



950

Art. 940 - 950
 Sedia Gliss girevole, regolabile in altezza con alzato a gas. Base in acciaio inox lucidato e colonna in acciaio cromato. Scocca in tecnopolimero bianco o sabbia (Art. 950). Disponibile la versione ad altezza fissa (Art. 940).
 Gliss swivel chair with gas lift device. Polished stainless steel base and chromed steel column. White or beige technopolymer shell (Art. 950). Fixed height version available (Art. 940).

Disponibile la versione imbottita sul catalogo TouchSOFT.
 Upholstered version available in our TouchSOFT catalogue.

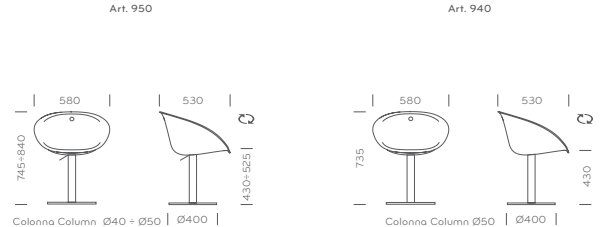

Gliss Tecnopolimero 153



Art. 904 - 905

Gliss si rinnova ed amplia la sua scelta di colori, strutture, materiali. Gliss Wood ha gambe in essenza di frassino, sbiancato o tinto nero, con scocca in tecnopolimero o policarbonato.
 Gliss, a contemporary star renovated by new material combinations for more versatile uses. Gliss Wood chair has bleached or black stained ash wooden legs with technopolymer or polycarbonate shell.

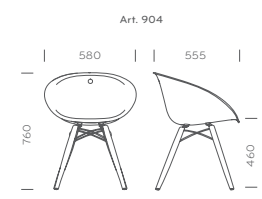

colori scocca / shell colours:



BI SA

finiture / finishes:



FR AN

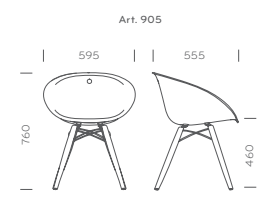

colori scocca / shell colours:



RT AT TR



VT FU NE

finiture / finishes:



FR AN



904



905



Art. 340 - 360

La sedia Gliss Lounge è dedicata a chi vuole rilassarsi senza rinunciare alla funzionalità e all'eleganza. Scocca in tecnopolimero accessoriabile con imbottitura sfoderabile, telaio a slitta in tondino d'acciaio oppure base centrale a 4 razze in pressofusione d'alluminio.
Gliss Lounge chair is dedicated to those who want to relax without renouncing at functionality and elegance. Technopolymer shell upholstered with removable cover, steel rod frame or die-casted aluminium central base with 4 feet available.

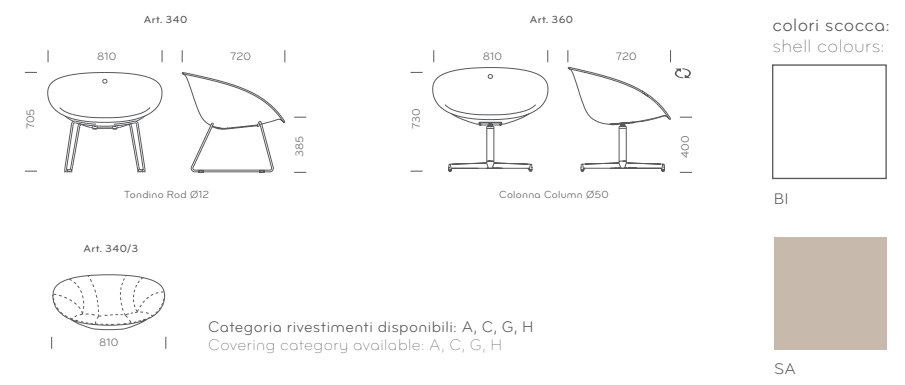

340 + 340/3



360

Art. 350

Gliss Swing è la versione a dondolo con scocca in tecnopolimero e telaio in tondino su cui sono montati i due pattini in essenza di frassino.
Gliss Swing rocking chair with technopolymer shell and two blocks in ash wood assembled on the steel rod frame.



350



158 Gliss Tecnopolimero

Art. 943 - 944
 Gliss sistema a tre o quattro sedute. Scocche in tecnopolimero bianco o sabbia. Basi e struttura in acciaio inox satinato.
 Gliss benches, three or four seats with white or beige technopolymer shell. Brushed stainless steel frame.

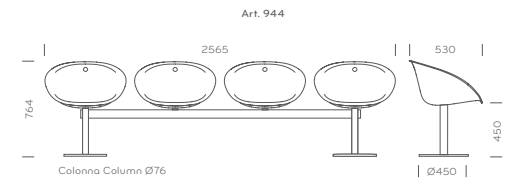
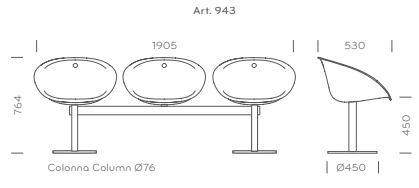

colori scocca / shell colours:
 SA BI



Art. 945
 Gliss versione con tre sedute e ripiano in laminato bianco e bordo in ABS satinato.
 Gliss bench, three seats version with white laminate top and satine ABS edge.

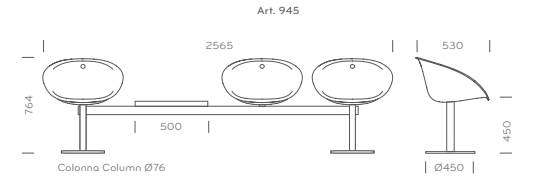

160 Kuadra XL Tecnopolimero

Developed by Pedrali R&D

Art. 2401 - 2403

Linee geometriche ed essenziali per Kuadra XL con scocca in tecnopolimero, materiale dalla rinomata resistenza e qualità estetica. Disponibile nei colori bianco, sabbia, rosso e nero. Telaio in tubo d'acciaio 20x20mm cromato, satinato o verniciato in tinta con la scocca oppure Ø 16 mm cromato o verniciato.

Minimalistic shape for Kuadra XL with technopolymer shell, material from the renowned quality performance and aesthetic qualities. Available in white, beige, red or black colours. 20x20mm square steel tube frame in chromed, satinized or powder coated in the same colour of the shell, or Ø 16 mm steel tube frame in chromed or satinized finish.

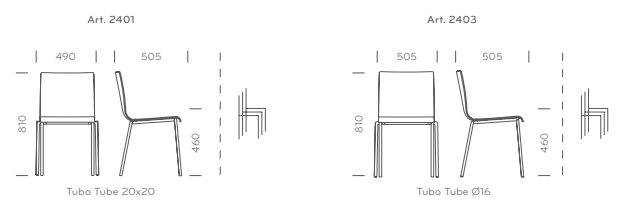

colori scocca:
shell colours:

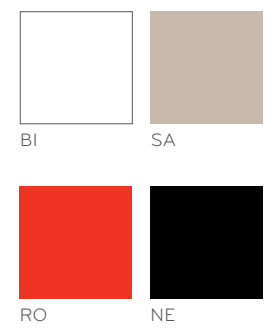

2403



2401



2403

Art. 2402 - 2404

Kuadra XL in tecnopolimero versione poltrona. Leggera e versatile, è l'ideale per collocazioni contract e corporate. Impilabile.
Kuadra XL armchair with technopolymer shell. Lightweight and versatile, ideal for contract and corporate situations.

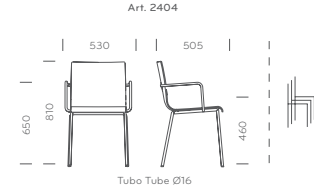
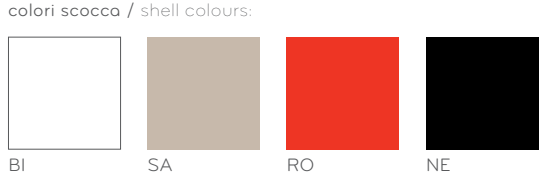
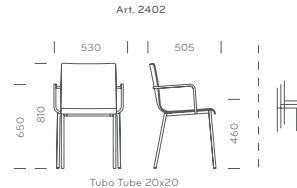

2402



La parte interna della scocca ha finitura opaca, la parte esterna semilucida.
Front part is matt finish, back part is semi-glossy finish.



2404

1oz light Rum
 1oz pineapple juice
 1/2 sp maraschino liqueur
 1/2 tsp green anise
 Garnish: ch
 Glassware: co

• APPLE BRANDY

1oz brandy
 1/2 oz apricot liqueur
 1/2 lemon juice
 1/2 orange juice
 Glassware: cocktail glass

ZESTY NEGRONI

1oz aperol
 1/4 oz sweet vermouth
 Garnish: orange twist



Art. 1271

Kuadra in policarbonato trasparente con telaio in tubolare d'acciaio satinato (Art. 1271) e tavolo Inox (Art.4402/AC) con ripiano in stratificato Compact Full Colour.
 Kuadra transparent polycarbonate chair with satinized steel tube frame (Art. 1271) and Inox table (Art. 4402/AC) with Compact Full Colour solid laminate top.

Kuadra Policarbonato 165



Art. 1271

Sedia Kuadra in polycarbonato nella versione trasparente o full colour. Il polycarbonato è resistente e flessibile e mantiene le doti di brillantezza e intensità di colore costanti nel tempo. Telaio in tubolare da mm 20x20 disponibile satinato, cromato o verniciato. Disponibile il carrello, per movimentare sino a dodici sedie.

Kuadra chair in transparent or full colour polycarbonate shell. Polycarbonate, strong and flexible at the same time, keeps unchanged its brightness and colour intensity. Satinized, chromed or powder coated tube frame 20x20 mm. Chair trolley available, to move up to twelve stacked chairs.

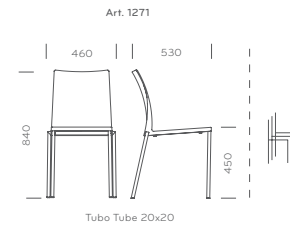

colori scocca / shell colours:



TR GT AT RT



BI NE



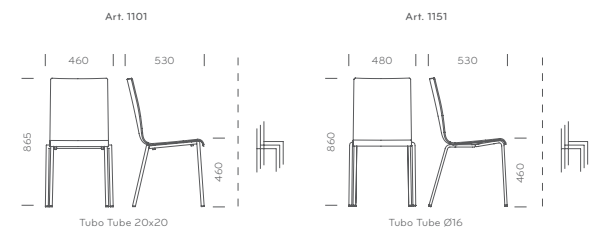

Art. 1101-1151
 Sedia Kuadra con scocca in tecnopolimero composito bianco o avorio, materiale dalla notevole resistenza e flessibilità, resistente ai graffi. Disponibile nella versione con telaio in tubolare d'acciaio 20x20 mm cromato, satinato o verniciato, oppure nella versione con telaio in tubo Ø 16 mm verniciato, cromato, cromato opaco.
 Kuadra chair, white or ivory technopolymer shell, flexible, strong and scratch resistant material. 20x20 mm chromed, satinized and powder coated steel tube frame or Ø16 mm powder coated, chromed or matt chromed.

Disponibile la versione sgabello sul catalogo KeepingHigh.
 Stool version in our KeepingHigh catalogue.

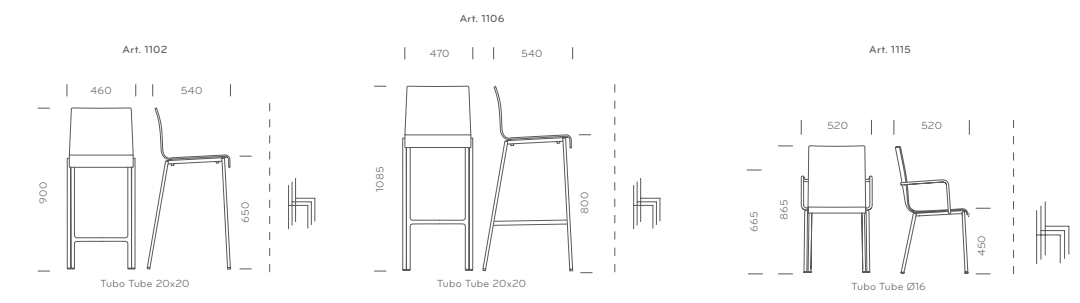

Art. 1101 - Sedia Kuadra e tavolo modello Inox (Art. 4441/AC).
 Kuadra chair and Inox table (Art. 4441/AC).



1101

1151



1115



Art. 1151 - Kuadra in tecnopolimero e tavolo modello Inox (Art. 4402/AC) con ripiano in laminato bordo ABS satinato.
 Kuadra chair with technopolymer shell and Inox table (Art. 4402/AC) with laminate top and satinized ABS edge.

Art. 1158

Sedia Kuadra con scocca in tecnopolimero e telaio in tondino Ø 10 mm.
 Impilabile. Disponibile il carrello, per movimentare sino a quindici sedie.
 Kuadra chair with technopolymer shell and Ø 10 mm steel rod frame.
 Stackable. Chair trolley available, to move up to fifteen stacked chairs.

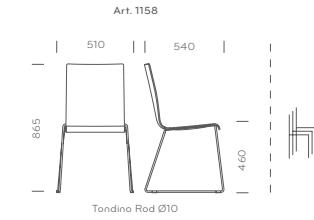

Kuadra Tecnopolimero 171



Art. 1171
 Sedia Kuadra in metacrilato curvato, spessore della scocca mm 10. Disponibile nei colori trasparente, opale, blu, rosso, marrone e grigio con telaio in acciaio da 20x20mm satinato, cromato o verniciato oppure in tubo cromato Ø 16 mm (Art. 1170). Disponibile la versione sgabello con scocca in metacrilato sia trasparente lucido che sabbato.
 Kuadra chair, shell in curved methacrylate, 10 mm thickness. Available in transparent colours, opaline, blue, red, brown and grey with 20x20 mm steel frame chromed, satinized, powder coated or with Ø16 mm chromed tube frame. Barstool version also available, both glossy or sandblasted transparent version.

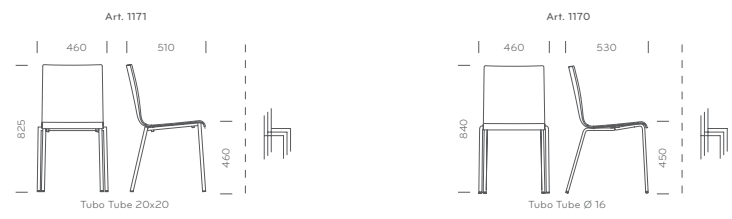

colori scocca:
 shell colours:

OP	RT
MT	BT
GG	TR

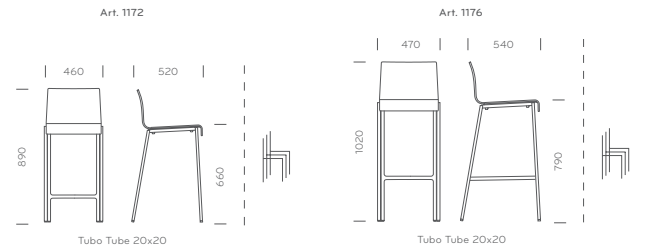

Sedia Kuadra in metacrilato sabbato (Art. 1171) e tavoli Zenith (Art. 4741/AC) in acciaio inox con ripiano in stratificato Compact Full Colour.
 Kuadra sand-blasted methacrylate (Art. 1171) and stainless steel Zenith tables (Art. 4741/AC) with compact Full Colour solid laminated top.



Design Alessandro Busana

Art. 630



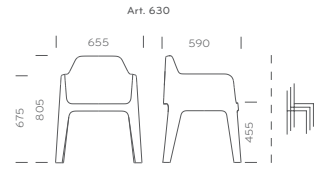



Caratterizzata da linee semplici e pulite, la poltroncina Plus è realizzata interamente in polipropilene. La forma unisce la fisicità della poltroncina da salotto alla praticità della poltroncina da esterni.
Featured by simple and clean lines, Plus has the shapes of a typical living room armchair combined with the versatility of an outdoor armchair.





Art. 630
Plus è disponibile in 6 colori: bianco, sabbia, marrone, verde, grigio antracite e arancio.
Impilabile, Plus è eco-friendly.
6 colours available: white, beige, brown, green, anthracite gray and orange.
Stackable, Plus is eco-friendly.

colori / colours:

		
BI	SA	MA
		
AR	GA	VE





180 Plus

Art. 630

Comoda e versatile, Plus è l'ideale per i contesti contract sia indoor che outdoor.
Comfortable and versatile, Plus is ideal both for indoor and outdoor contract environments.





Art. 630.3

Il cuscino aumenta il comfort della seduta Plus senza rinunciare alla funzionalità. Imbottito con schiuma di poliuretano espanso e rivestito in tessuto idropassante in modo da favorire il deflusso dell'acqua e da consentire l'utilizzo outdoor. The cushion makes the seat of Plus more comfortable without renouncing at functionality. It's upholstered with injected polyurethane foam and covered with fabric, which weeve allows the water drainage. Suitable for outdoor use.



Plus 183

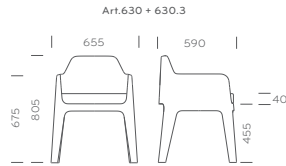

cuscino / cushion:



630 + 630.3

Design Alessandro Busano





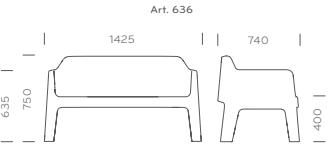
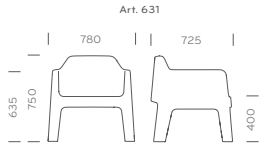

Art. 631 - 636

Plus Air poltrona lounge e divano derivano dal concept di Plus. Realizzati in polietilene con la tecnica dello stampaggio rotazionale, sono disponibili in bianco, rosso e grigio antracite. Curve e superfici originarie trovano nuove proporzioni per offrire un elevato comfort di seduta. Plus Air lounge armchair and Plus Air sofa versions come from the concept of the Plus seatings. Made of polyethylene with rotational moulding technology, they are available in white, red or anthracite gray colours. The easy-chic stylish contents of Plus live again under a new look.



colori / colours:

		
BI	GA Solo per utilizzo interno For indoor use only	RO



631



636



Art. 636.3 - 631.3

Plus Air divano e poltrona lounge sono ideali sia per indoor che per outdoor. Accessoriabili con cuscino in tessuto per esterni. L'ampio foro di scolo per l'acqua che è anche un utile punto di presa per facilitare lo spostamento.
Plus Air sofa and Plus Air lounge armchair versions, like the Plus, are suitable for indoors and outdoors. They can be equipped with a fabric cushion for outdoor. The large water drain hole is also a useful handle to move it easier.

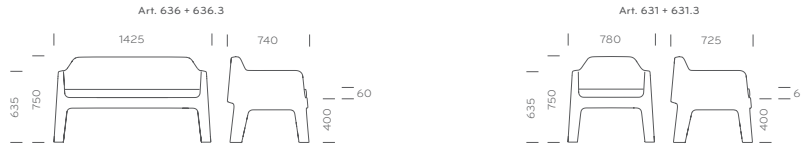

cuscino / cushion:



636 + 636.3





Design Claudio Dondoli and Marco Poggi

Art. 306
Poltrona Tatami è in polipropilene; leggera ed allo stesso tempo stabile. Resistente ai raggi UV e all'acqua è ideale per uso esterno. Impilabile.
Tatami armchair in polypropylene, lightweight and stable at the same time. Resistant to UV-beams, suitable for outdoor use, stackable.

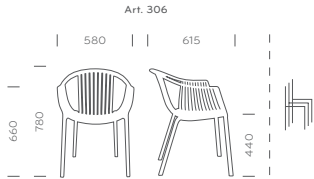

colori / colours:

BI	RO
VE	MA
GA	SA





Art. 306

Ideale per piazze e caffetterie all'aperto, Tatami è disponibile in 6 colori naturali: bianco, rosso, verde, sabbia, marrone e grigio antracite.
Ideal for squares and open-air bars, Tatami is available in 6 natural shades of colour: white, red, green, beige, brown and anthracite gray.





Art. 306

Eco-friendly, Tatami è 100% riciclabile.
Eco-friendly Tatami 100% recyclable.



Tatami 195





Art. 305
 Tatami in versione sedia ha sedile e schienale intrecciati. Realizzata completamente in polipropilene, è disponibile in 6 colori naturali.
 Tatami chair version, seat and back with the typical weave shape. Completely in polypropylene, available in 6 natural shades of colour.

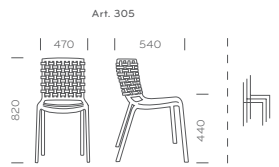

colori / colours:

BI	RO
VE	MA
GA	SA





Design Claudio Dondoli and Marco Poggi

Art. 800

La sedia Ice è disponibile in 8 colori: arancio, verde, rosso, avorio, marrone, grigio antracite, azzurro e nero. Impilabile.
Ice chair, stackable, is available in 8 colours: orange, green, red, ivory, brown, black, anthracite grey and light blue. Stackable.

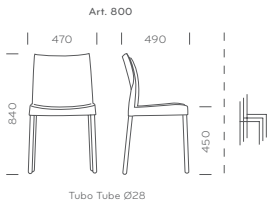

colori scocca / shell colours:

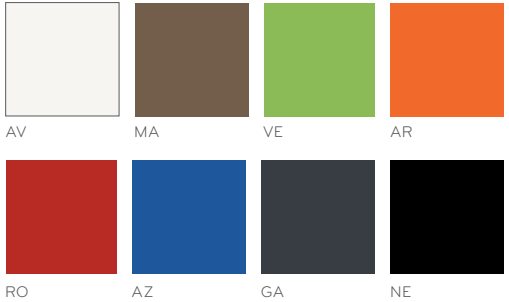





Art. 800

Ice realizzata in polipropilene resistente ai raggi UV, con gambe in tubo di alluminio anodizzato Ø 28 mm che ne consentono l'utilizzo anche in esterno.
Ice made with UV rays resistant polypropylene and anodized aluminium tube legs Ø28mm. Suitable also for outdoor use.



Art. 800 - Sedia Ice e tavolo Plastic-X (Art. 4740) con ripiano in polietilene
Ice chair and Plastic-X table (Art. 4740) with polyethylene top.



Art. 840

Gancio di collegamento laterale per sedia e poltrona Ice. Realizzato in nylon colore grigio.
Side linking device for Ice chair and armchair in grey nylon.

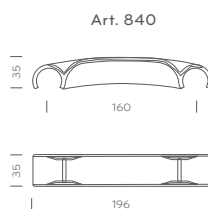



Art. 850
Poltroncina Ice e tavolo Dream
verniciato bianco (Art. 4830) con
ripiano in laminato.
Ice armchair and Dream white
powder-coated table (Art. 4830)
with laminate top.



Art. 850

Ice versione poltrona è realizzata in polipropilene resistente ai raggi UV con gambe in tubo di alluminio anodizzato Ø 28 mm, materiali che lo rendono ideale per l'esterno. Disponibile in 7 colori: arancio, verde, rosso, avorio, grigio antracite, marrone e azzurro. Accessoriabile con gancio di collegamento.

Ice armchair, shell in UV rays resistant polypropylene, Ø 28 mm round anodized aluminium tube legs. Suitable also for outdoor use. Available in 7 colours: orange, green, red, ivory, anthracite grey, brown and light blue. Linking device available.

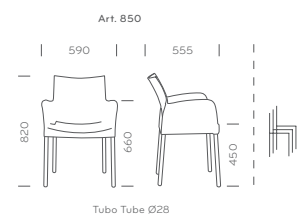

colori scocca / shell colours:

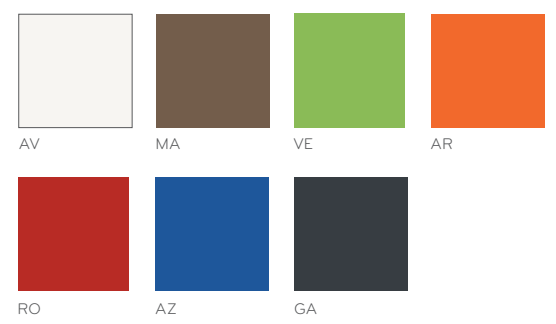

Design Claudio Dondoli and Marco Poggi



Art. 600
Realizzata completamente in nylon, Smart è caratterizzata dalla veletta anteriore e dalle affusolate gambe posteriori. Smart è disponibile nei colori bianco, rosso e nero. Impilabile.
Smart chair, completely made of nylon, featured by front veil and back tapered legs. Smart chair is available in white, red and black. Stackable.

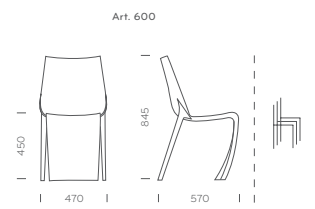

Developed by Pedrali R&D



Art. Miss Alù - Mrs Alù
Miss Alù in pressofusione di alluminio con sedile e schienale in polipropilene nei colori: bianco, arancio, rosso, blu, nero e verde.
Miss Alù side-chair with die-casted aluminium frame, polypropylene seat and back available in white, orange, red, blue, black and green.

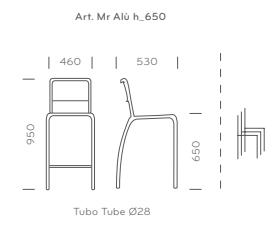
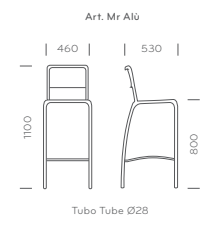
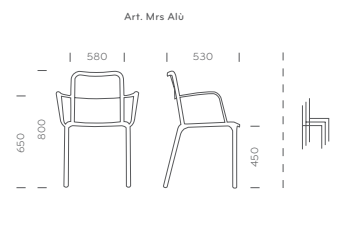
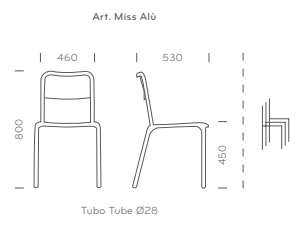

colori scocca / shell colours:

BI	AR	RO	VE	BL	NE
----	----	----	----	----	----



220 Host Lounge

Design Claudio Dondoli and Marco Poggi

Art. 790 - 792

Sistema di sedute modulari composto da due elementi, diversamente accostabili: seduta singola e seduta singola con schienale. Scocca in polietilene e telaio in acciaio inox Aisi 316L, ideale per l'utilizzo all' esterno. Colori disponibili: bianco, rosso e nero. Accessoriabile con gancio di collegamento.
Informal modular sitting system, composed by two elements variously joinable: single seat unit and single seat backrest unit. Polyethylene shell and stainless steel Aisi 316L tube frame, suitable for outdoor use. Colours: white, red and black. Linking device available.

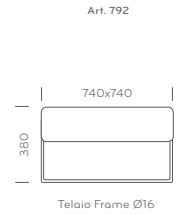
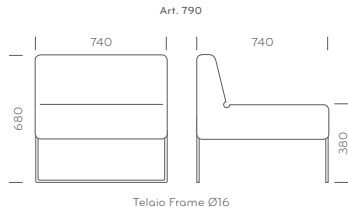

colori / colours:



Gancio di collegamento.
Linking device.



Art. 790/G_NE

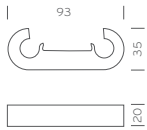

790



















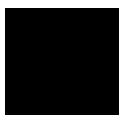





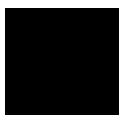





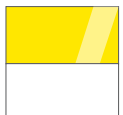





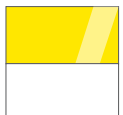

Wow e Host sono in polietilene resistente ai raggi UV, adatti per esterno.
Wow and Host are made of UV rays resistant polyethylene, suitable for outdoor use.

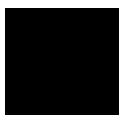
Design Claudio Dondoli and Marco Poggi

Art. 480 - 482 - 483 - 470 - 472 - 473

Wow, pouf sgabello in polietilene colorato che capovolto diventa tavolino-contenitore grazie all'appoggio di un piano in metacrilato bicolore. Disponibile in due dimensioni Ø400 mm (Art. 480) e Ø660mm (Art. 470). Lo sgabello può montare una base cromata.

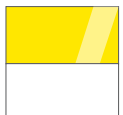



Wow, coloured polyethylene low stool, once upturned it becomes a low table/storage thanks to a methacrylate double face top. Two different sizes available: Ø400 mm (Art. 480) and Ø660mm (Art. 470). Wow stool can be completed by a chromed base.

 <p>Contenitore / Sgabello Storage / Stool</p>	<p>Piano Top</p> <table border="0"> <tr> <td>Art. 482 Ø380</td> <td>Art. 472 Ø635</td> </tr> </table>	Art. 482 Ø380	Art. 472 Ø635	<p>Colore contenitore: Storage colour:</p> <table border="0"> <tr> <td></td> <td></td> </tr> <tr> <td>CI</td> <td>VE</td> </tr> <tr> <td></td> <td></td> </tr> <tr> <td>RO</td> <td>NE</td> </tr> <tr> <td></td> <td></td> </tr> <tr> <td>BI</td> <td>GI</td> </tr> </table>			CI	VE			RO	NE			BI	GI	<p>Colore ripiano: Top colour:</p> <table border="0"> <tr> <td></td> <td></td> </tr> <tr> <td>CI_BI</td> <td>VE_BI</td> </tr> <tr> <td></td> <td></td> </tr> <tr> <td>RO</td> <td>BI_NE</td> </tr> <tr> <td></td> <td></td> </tr> <tr> <td>GI_BI</td> <td></td> </tr> </table>			CI_BI	VE_BI			RO	BI_NE			GI_BI	
	Art. 482 Ø380	Art. 472 Ø635																											
																													
CI	VE																												
																													
RO	NE																												
																													
BI	GI																												
																													
CI_BI	VE_BI																												
																													
RO	BI_NE																												
																													
GI_BI																													
<table border="0"> <tr> <td>Art. 480 460 Ø400</td> <td>Art. 470 290 Ø660</td> </tr> </table>	Art. 480 460 Ø400	Art. 470 290 Ø660																											
Art. 480 460 Ø400	Art. 470 290 Ø660																												
<p>Base Cromata Chromed Base</p> <table border="0"> <tr> <td>Art. 483 Ø375</td> <td>Art. 473 Ø630</td> </tr> </table>	Art. 483 Ø375	Art. 473 Ø630																											
Art. 483 Ø375	Art. 473 Ø630																												





 Noa

 NERO / Verniciato Nero Black Powder Coated	 BI / Verniciato Bianco White Powder Coated	 CR / Acciaio Cromato Chromed Steel	 LU / Alluminio lucidato Polished aluminium
--	--	--	--



 Day Dream

 CR / Acciaio Cromato Chromed Steel	 NERO / Verniciato Nero Black Powder Coated	 BI / Verniciato Bianco White Powder Coated	 CO / Cromato opaco Mat chromed	 ALE / Verniciato Alluminio per esterno Silver Powder Coated for outdoor use
---	---	---	---	--



 Babila

 CR / Acciaio Cromato Chromed Steel	 BI / Verniciato Bianco White Powder Coated	 BE / Verniciato Beige Beige Powder Coated	 NERO / Verniciato Nero Black Powder Coated
--	--	---	--

 Mya

 BI / Verniciato Bianco per esterno White Powder Coated for outdoor use	 GA / Verniciato grigio per esterno Grey Powder Coated for outdoor use	 NERO / Verniciato Nero per esterno Black Powder Coated for outdoor use	 SA / Verniciato Sabbia per esterno Beige Powder Coated for outdoor use	 RO / Verniciato Rosso per esterno Red Powder Coated for outdoor use	 LU / Alluminio lucidato Polished aluminium	 ST / Alluminio satinato Brushed aluminium
--	---	---	--	---	--	---

 Grace

 NERO / Verniciato Nero Black Powder Coated	 BI / Verniciato Bianco White Powder Coated	 AR / Verniciato Arancio Orange Powder Coated	 ALE / Verniciato Alluminio per esterno Silver Powder Coated for outdoor use
 CR / Acciaio Cromato	 AC / Acciaio Inox Satinato per esterno Brushed Stainless Steel for outdoor use		

Joi



ST / Alluminio Anodizzato Satinato per esterno
Satin Anodized Aluminium for outdoor use

Ice



AA / Alluminio Anodizzato per esterno
Anodized Aluminium for outdoor use

Kuadra XL



NERO / Verniciato Nero
Black Powder Coated

RO / Verniciato Rosso
Red Powder Coated

SA / Verniciato Sabbia
Beige Powder Coated

BI / Verniciato Bianco
White Powder Coated



ST / Acciaio Satinato
Satinized Steel

CR / Acciaio Cromato
Chromed Steel

Koi-Booki



BI / Verniciato Bianco
White Powder Coated

SA / Verniciato Sabbia
Beige Powder Coated

NERO / Verniciato Nero
Black Powder Coated

AR / Verniciato Arancio
Orange Powder Coated

BL / Verniciato Blu
Blu Powder Coated

Gliss

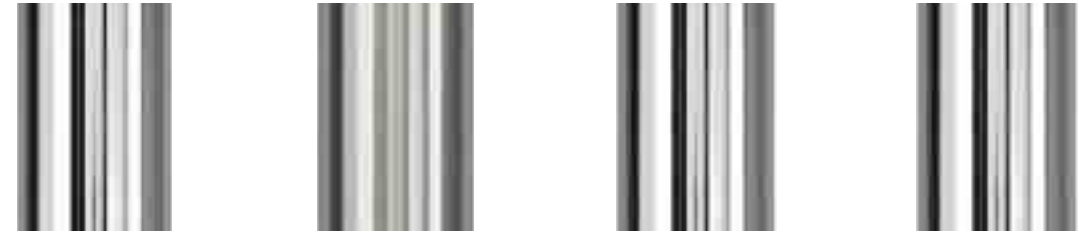

CR / Acciaio Cromato
Chromed Steel

AC / Acciaio Inox Satinato
Brushed Stainless Steel

LU / Acciaio Inox Lucido
Polished Stainless Steel

AS / Alluminio lucido
Polished Aluminium



NERO / Verniciato Nero
Black Powder Coated

BI / Verniciato Bianco
White Powder Coated

Kuadra



ST / Acciaio Satinato
Satinized Steel

CR / Acciaio Cromato
Chromed Steel

AL / Verniciato alluminio
Silver Powder Coated

AG / Verniciato alluminio goffrato
Mat silver powder coated



NERO / Verniciato Nero
Black Powder Coated

BI / Verniciato Bianco
White Powder Coated

CO / Cromato opaco
Mat chromed

AC / Acciaio Inox Satinato
Brushed Stainless Steel

232

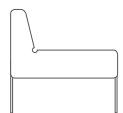

Host Lounge

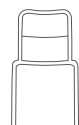

Alù

AC AISI 316 / Acciaio Inox per esterno
Brushed stainless steelCR / Acciaio Cromato
Chromed SteelALE / Verniciato alluminio
per esterni
Silver Powder Coated
for outdoor use

Tweet

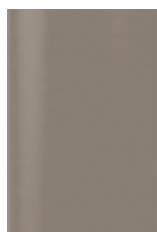
BI / Verniciato Bianco
White Powder CoatedGA / Verniciato grigio
antracite
Anthracite grey
powder coatedBE / Verniciato Beige
Beige Powder CoatedVE / Verniciato verde
lucido
Green powder
coated, shiny
finishAF / Verniciato arancio
lucido
Orange powder
coated, shiny finishRO / Verniciato rosso
lucido
Red powder
coated, shiny
finishNERO / Verniciato Nero
Black Powder CoatedCR / Acciaio Cromato
Chromed SteelCN / Cromato nero
Black chromedThe mark of
responsible forestryCerca i prodotti certificati FSC™
Look for FSC™ certified products

Pesi, dimensioni e colori sono indicativi. Pedrali si riserva la facoltà di apportare modifiche o migliorie senza alcun preavviso.
Weight, sizes and colours are approximate. Pedrali reserves the right to modify or upgrade the product without prior notice.

Tutte le collezioni Pedrali sono protette nel mondo dal diritto di proprietà industriale e da brevetti registrati.

All Pedrali collections are protected throughout the world by industrial design, patent and copyright registries.

Catalogo SuperPlastic | Edizione Novembre 2014

Progetto grafico e art direction: Borgo Creativo

Foto: Ezio Manciucca + Davide Cerati + Studio Odeon + Ottavio Tomasini + Beppe Brancato

Styling: Cristina Pasini + Silvia Valassina e Barbara Mantovani | Stampa: Intese Grafiche

Thanks to: Paola C. + B. Morone + Carlo Moretti. + Zanetto Argenti + Blue distribution + Wesc

Copyright Pedrali 2014