

EOS

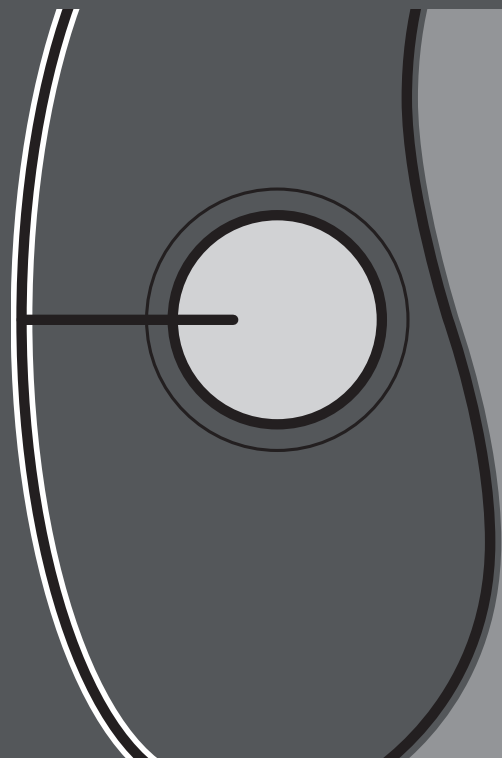

EOS furnishes the reception area with bright colourful solutions, which include three structural elements: a front wall with an aluminium frame and a filler panel in acrylic, fabric or wood - chipboard side panels - and a reception top in back-lacquered glass with aluminium profile with polished brushed finish or wood finish. The EOS reception counter can be matched with all Alea work desk collections.

EOS décore la zone accueil avec des solutions lumineuses et colorées, en associant entre eux trois éléments de structure: - un panneau avant avec cadre aluminium et habillage en acrylique, en tissu ou en bois, - des panneaux latéraux en bois - un plateau supérieur en verre rétro laqué avec profil en aluminium brossé brillant ou bien en finition bois. La banque d'accueil EOS est disponible avec des finitions assorties aux plateaux de toutes les collections Alea.

EOS bietet für den Empfangsbereich leuchtende und farbenfrohe Einrichtungslösungen, die sich aus drei verschiedenen Strukturelementen zusammensetzen: einem Frontpaneel mit Aluminiumrahmen und Füllung aus Acryl, Stoff oder Holz - seitlichen Paneelen aus Holz - einer Rezeptionsplatte aus rückseitig lackiertem Glas mit Profil aus glänzendem gebürstetem Aluminium oder in Holz Ausführung. Das Rezeptionspult EOS kann mit allen Tischen der Kollektionen Alea kombiniert werden.

EOS decora la zona de recepción con luminosas soluciones de colores que combinan tres elementos estructurales: una pared frontal con marco de aluminio y relleno de acrílico, tejido o madera, los paneles laterales de madera y una encimera de cristal retrolacado con perfil de aluminio cepillado brillante o en acabado madera. El banco de recepción EOS puede combinarse con las mesas de todas las colecciones Alea.

EOS arreda la zona ricevimento con soluzioni luminose e colorate, combinando tra loro tre elementi strutturali: una parete frontale con telaio alluminio e riempimento in acrilico, tessuto o legno - i pannelli laterali lignei - un top reception in vetro retrolaccato con profilo in alluminio spazzolato lucido oppure in finitura legno. La reception EOS si abbina ai tavoli di tutte le collezioni Alea.







Gli elementi costitutivi sono modulari e facilmente adattabili. La struttura di EOS è autoportante e indipendente dal tavolo lavoro. I pannelli lignei laterali sono dotati di profilo metallico dove agganciare utili accessori quali mensole, portacarte e portadocumenti.

All components are modular and adapt easily. The structure of EOS is self-supporting and separate from the work desk. Its chipboard side panels are equipped with a metal profile, where useful accessories can be attached, such as shelves, paper trays and document trays.

Les éléments composants la banque d'accueil sont modulaires et facilement intégrables. La structure de EOS est autoportante et donc indépendante du plan de bureau. Les panneaux latéraux en bois sont dotés d'un profil métallique sur lequel on peut accrocher des accessoires comme des étagères, des range-dossiers et des range-documents.

Die Bauelemente sind modular und daher mühelos einsetzbar. Die Struktur von EOS ist selbsttragend und völlig unabhängig von den Arbeitstischen. Die seitlichen Paneele aus Holz sind mit Metallprofilen ausgestattet, in die nützliche Zubehörteile wie Borde, Aktenablagen und Stifthalter eingehakt werden können.

Los elementos que lo constituyen son modulares y fáciles de adaptar. La estructura de EOS es autoportante e independiente de la mesa de trabajo. Los paneles de madera laterales están dotados de un perfil metálico donde pueden engancharse útiles accesorios como baldas, portapapeles y portadocumentos.





EOS





Pannelli Panels Panneaux Paneele Paneles

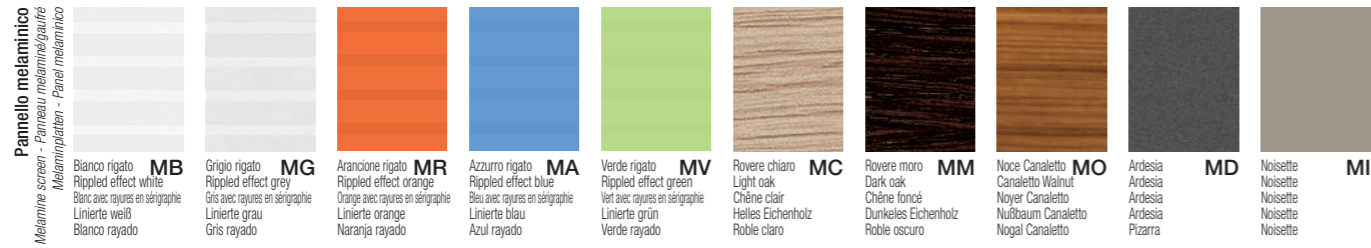

Mensola reception Reception top Support accueil Rezeptionsplatte Estante mostrador



Pannelli screen Screen panels Panneaux cloison Paneele für Screen Paneles screen

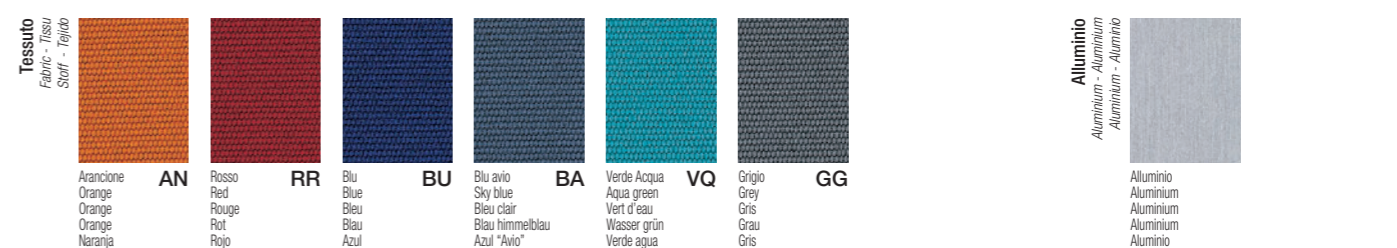
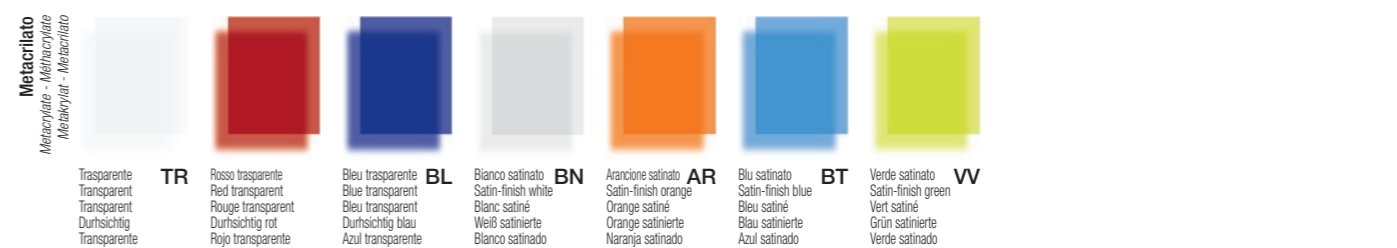
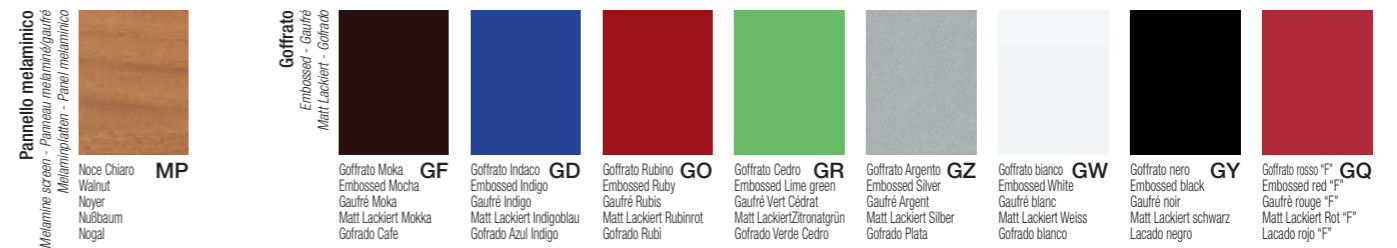
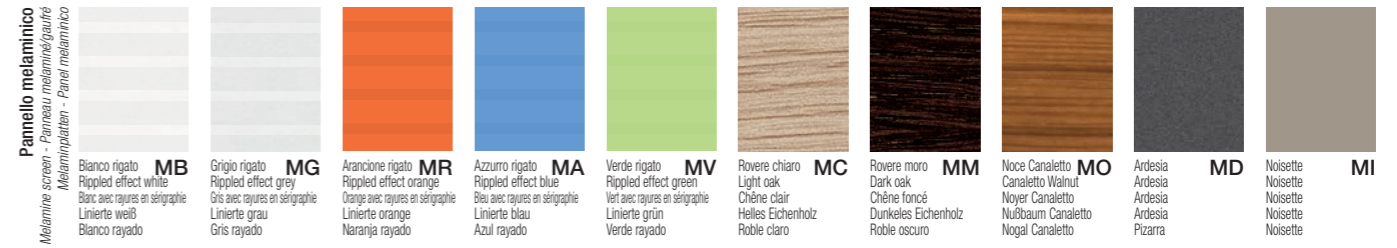

Screen superiore in metacrilato Upper acrylic screen Ecran pour superposition em méthacrylate Acryglas Aufsatz Screen Paneel Screensuperior en metacrilato

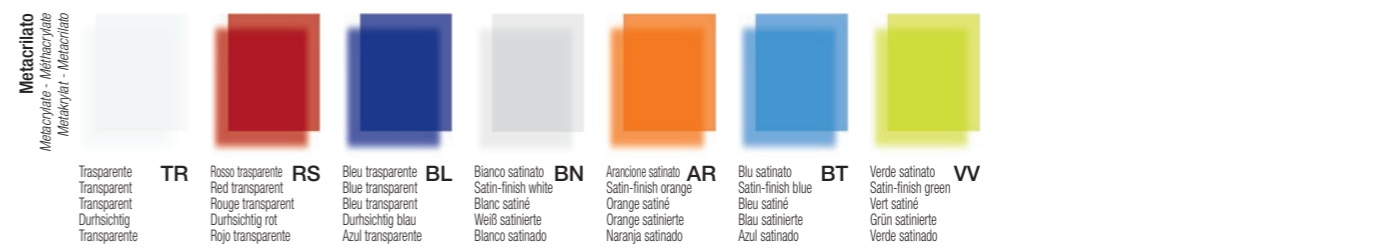

Mensola P.30 - 6038

L. 60	23 10/16	Cod.06003 /V
L. 70	27 9/16	Cod.07003 /V
L. 80	31 8/16	Cod.08003 /V
L. 90	35 7/16	Cod.09003 /V
L. 100	39 6/16	Cod.10003 /V
L. 110	43 5/16	Cod.11003 /V
L. 120	47 4/16	Cod.12003 /V
L. 130	51 3/16	Cod.13003 /V
L. 140	55 2/16	Cod.14003 /V
L. 150	59 1/16	Cod.15003 /V
L. 160	63	Cod.16003 /V
L. 170	66 15/16	Cod.17003 /V
L. 180	70 14/16	Cod.18003 /V
L. 190	74 13/16	Cod.19003 /V
L. 200	78 12/16	Cod.20003 /V
L. 210	82 11/16	Cod.21003 /V
L. 220	86 10/16	Cod.22003 /V
L. 230	90 9/16	Cod.23003 /V
L. 240	94 8/16	Cod.24003 /V
L. 250	98 7/16	Cod.25003 /V
L. 260	102 6/16	Cod.26003 /V
L. 270	106 5/16	Cod.27003 /V
L. 280	110 4/16	Cod.28003 /V
L. 290	114 3/16	Cod.29003 /V
L. 300	118 2/16	Cod.30003 /V

Fianco H.105 - 6086

L. 30	11 13/16	Cod.030105
L. 40	15 12/16	Cod.040105
L. 50	19 11/16	Cod.050105

Fianco H.105 - 6086

L. 60	23 10/16	Cod.060105
L. 70	27 9/16	Cod.070105
L. 80	31 8/16	Cod.080105
L. 90	35 7/16	Cod.090155
L. 100	39 6/16	Cod.100105
L. 110	43 5/16	Cod.110105
L. 120	47 4/16	Cod.120105
L. 130	51 3/16	Cod.130105
L. 140	55 2/16	Cod.140105
L. 150	59 1/16	Cod.150105
L. 160	63	Cod.160105
L. 170	66 15/16	Cod.170105
L. 180	70 14/16	Cod.180105
L. 190	74 13/16	Cod.190105
L. 200	78 12/16	Cod.200105
L. 210	82 11/16	Cod.210105
L. 220	86 10/16	Cod.220105
L. 230	90 9/16	Cod.230105
L. 240	94 8/16	Cod.240105
L. 250	98 7/16	Cod.250105
L. 260	102 6/16	Cod.260105
L. 270	106 5/16	Cod.270105
L. 280	110 4/16	Cod.280105
L. 290	114 3/16	Cod.290105
L. 300	118 2/16	Cod.300105

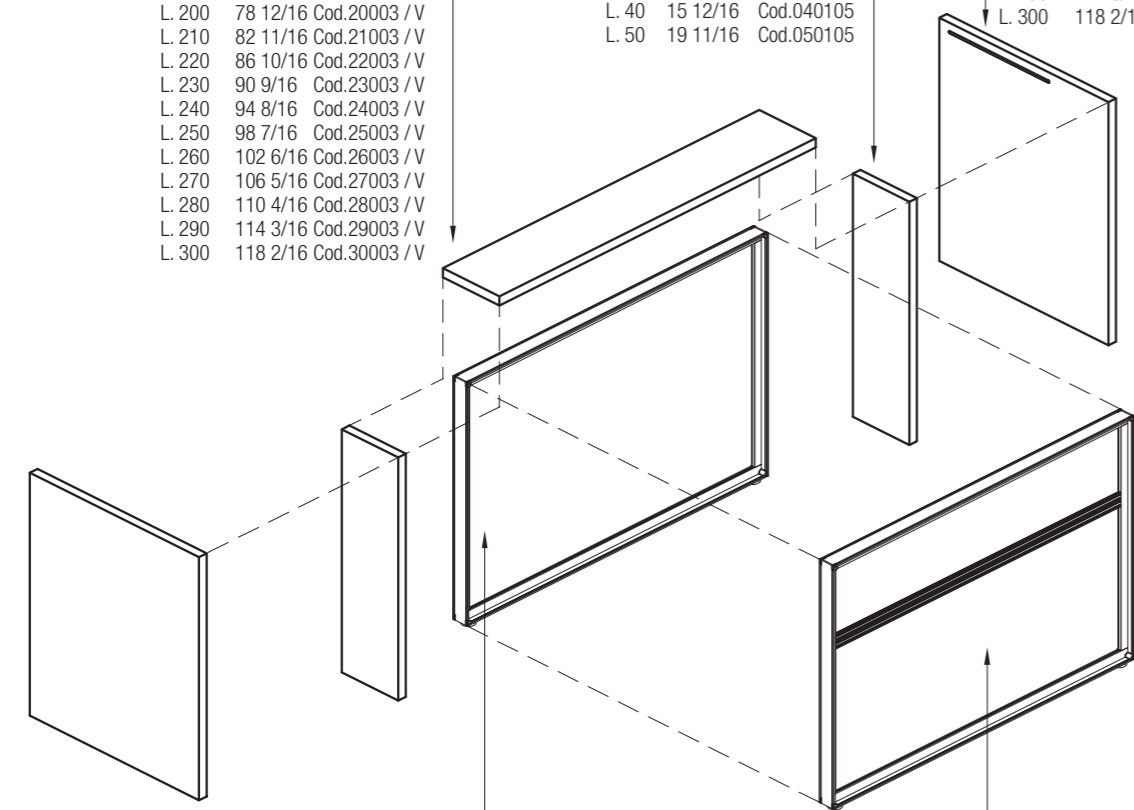

Telaio screen H.105 - 6020

L. 50	19 11/16	Cod.051	L. 180	70 14/16	Cod.181
L. 60	23 10/16	Cod.061	L. 190	74 13/16	Cod.191
L. 70	27 9/16	Cod.071	L. 200	78 12/16	Cod.201
L. 80	31 8/16	Cod.081	L. 210	82 11/16	Cod.211
L. 90	35 7/16	Cod.091	L. 220	86 10/16	Cod.221
L. 100	39 6/16	Cod.101	L. 230	90 9/16	Cod.231
L. 110	43 5/16	Cod.111	L. 240	94 8/16	Cod.241
L. 120	47 4/16	Cod.121	L. 250	98 7/16	Cod.251
L. 130	51 3/16	Cod.131	L. 260	102 6/16	Cod.261
L. 140	55 2/16	Cod.141	L. 270	106 5/16	Cod.271
L. 150	59 1/16	Cod.151	L. 280	110 4/16	Cod.281
L. 160	63	Cod.161	L. 290	114 3/16	Cod.291
L. 170	66 15/16	Cod.171	L. 300	118 2/16	Cod.301

Telaio screen agganciato H.105 - 6020

L. 50	19 11/16	Cod.052	L. 180	70 14/16	Cod.182
L. 60	23 10/16	Cod.062	L. 190	74 13/16	Cod.192
L. 70	27 9/16	Cod.072	L. 200	78 12/16	Cod.202
L. 80	31 8/16	Cod.082	L. 210	82 11/16	Cod.212
L. 90	35 7/16	Cod.092	L. 220	86 10/16	Cod.222
L. 100	39 6/16	Cod.102	L. 230	90 9/16	Cod.232
L. 110	43 5/16	Cod.112	L. 240	94 8/16	Cod.242
L. 120	47 4/16	Cod.122	L. 250	98 7/16	Cod.252
L. 130	51 3/16	Cod.132	L. 260	102 6/16	Cod.262
L. 140	55 2/16	Cod.142	L. 270	106 5/16	Cod.272
L. 150	59 1/16	Cod.152	L. 280	110 4/16	Cod.282
L. 160	63	Cod.162	L. 290	114 3/16	Cod.292
L. 170	66 15/16	Cod.172	L. 300	118 2/16	Cod.302

Fianco H.105 - 6085

L. 90	35 7/16	Cod.090155
L. 100	39 6/16	Cod.100105
L. 110	43 5/16	Cod.110105
L. 120	47 4/16	Cod.120105
L. 130	51 3/16	Cod.130105
L. 140	55 2/16	Cod.140105
L. 150	59 1/16	Cod.150105
L. 160	63	Cod.160105
L. 170	66 15/16	Cod.170105
L. 180	70 14/16	Cod.180105
L. 190	74 13/16	Cod.190105
L. 200	78 12/16	Cod.200105
L. 210	82 11/16	Cod.210105
L. 220	86 10/16	Cod.220105
L. 230	90 9/16	Cod.230105
L. 240	94 8/16	Cod.240105
L. 250	98 7/16	Cod.250105
L. 260	102 6/16	Cod.260105
L. 270	106 5/16	Cod.270105
L. 280	110 4/16	Cod.280105
L. 290	114 3/16	Cod.290105
L. 300	118 2/16	Cod.300105

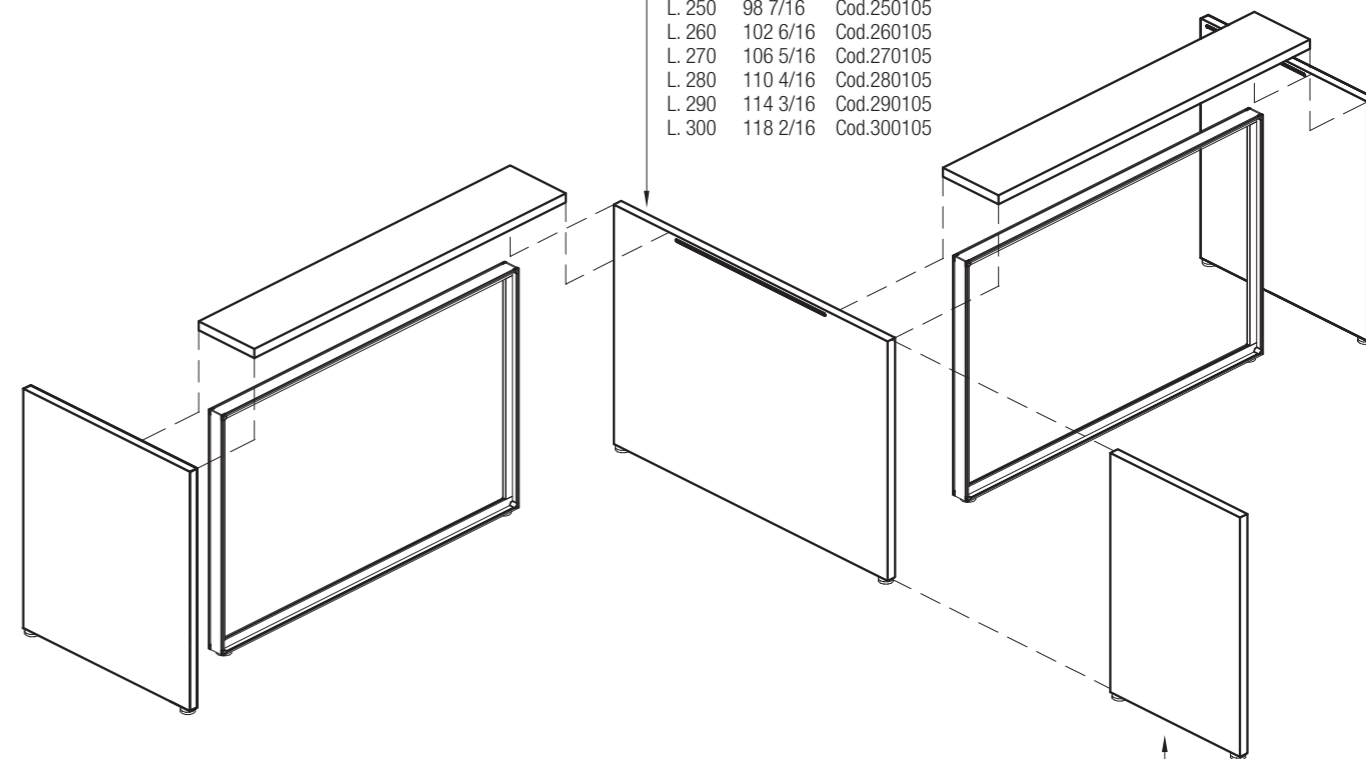

Fianco H.105 - 6085

L. 60	23 10/16	Cod.060105
L. 70	27 9/16	Cod.070105
L. 80	31 8/16	Cod.080105



design
Mirto Antonel & Filippon

art direction
Mirto Antonel

AL/CAAL/AB



ALEA srl - Via Col de Rust, 19 - 33070 Sarone (PN) - ITALIA
Tel. ++39.0434.777333 - Fax ++39.0434.779903
www.aleaoffice.com - e-mail: info@aleaoffice.com

ALEA USA INC. - 3449 NE 1st Avenue, Mews L-32 - Miami FL 33137
Tel. 305 470-1200 - Fax 305 470-9070
www.alea-usa.com - e-mail: info@alea-usa.com