

**PEDRALI S.p.A.**

sp 122 Mornico al Serio - 24050 BERGAMO - ITALY  
Export Dept. Tel: +39 035 8358840 Fax +39 035 8358888  
Ufficio Commerciale Italia Tel: +39 035 8358810 Fax +39 035 8358888

www.pedrali.it - info@pedrali.it

LIVENATURAL 2014

SEDUTE E TAVOLI

LIVENATURAL\_1412

**PEDRALI**

**PEDRALI**<sup>®</sup>  
DYNAMIC DESIGN

LIVENATURAL 2014

BOX Z BOX SIS MALM Ö F TWIG APPLE BOX NELLE A APPLE TWIG  
G N B ABILA J JACKIE X T E Y SURFACE M S SIGN N DRESS B ABILA A P P P L E A  
FACE GILDA PARENTHESIS TIVOLI S O N NOY SURFACE FRIDA BABILA E J I L LEILA U R E  
ZENSURFACE FEBRERA W S O N NOY SURFACE FRIDA BABILA E J I L LEILA U R E  
FEEL VOLING PARENTHESIS GILDA W S O N NOY SURFACE FRIDA BABILA E J I L LEILA U R E

LIVENATURAL 2014

Allure p.96



Gliss Wood p.52



Apple p.144



Jackie p.84

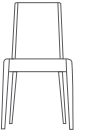

**NEW** Arki-Table Wood p.158



Jil p.106



**UPDATE** Babila p.20



Leila p.100



Box p.114

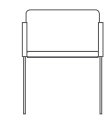

Malmö p.34



**UPDATE** Brera p.10



**NEW** Parenthesis p.156

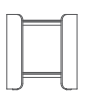

Dress p.80



Polo p.130



Elle p.102

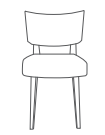

Sign p.86



Exteso p.150



Surface p.94

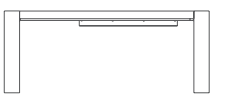

Feel p.54

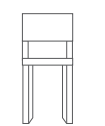

**NEW** Tivoli p.30



Frida p.04

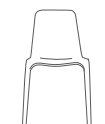

Twig p.76



Gilda p.134



Young p.62

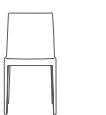

Glam p.124

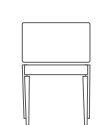

Zen p.140

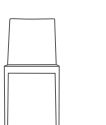

# 04 Frida

Design Odo Fioravanti



## Art. 752

Frida nasce dall'applicazione di un'esile struttura in rovere massiccio ad un sottile guscio in multistrati di pochi millimetri realizzato con la tecnologia del tranciato tridimensionale, che dona comfort alla seduta ed un nuovo appeal contemporaneo al legno. La parte strutturale è caratterizzata da sezioni a forma variabile: dal quadrato al rettangolo, forme che si assottigliano lungo i bordi per donare un'immagine leggera e dinamica.

Frida chair, slim solid oak frame and thin moulded plywood shell, thanks to the use of 3d-veneered technology, is an unbelievable lightweight chair with reduced profile, but at the same time with a high resistant construction. The rectangular rounded-off legs become triangular-shaped and grant to the chair a light and dynamic design.

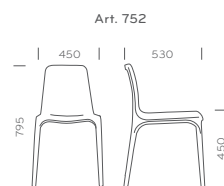



Art. 752

Un frame che spinge al massimo il limite della resistenza del legno per ottenere una seduta dall'estetica dinamica, che esalta la forza concettuale del guscio curvato spesso solo pochi millimetri.  
A frame that entirely exploits the limit of the wood resistance so to obtain a seating with a dynamic beauty. It enhances the conceptual strength of the few millilitres thickness curved shell.

Finiture: / Finishes:

			
W	GC	RS	BI Rovere laccato bianco poro aperto Open grains white lacquered oak



# 08 Frida

Art. 752

Frida è una sedia leggera ma al tempo stesso estremamente resistente. Pesa infatti solo 2,7 kg. Disponibile nelle finiture rovere sbiancato, tinto wengé, tinto grigio chiaro o laccato bianco.  
Frida chair is lightweight but resistant at the same time. Weights only kg 2,7. Bleached oak, wenge stained, light grey stained or white lacquered finishes available.





Design Pedrali R&amp;D

## Art. 380

Elegante e composta, Brera è caratterizzata da dimensioni contenute e al tempo stesso un grande comfort di seduto.  
Elegant and composed, Brera is characterized by small sizes and a great sitting comfort of the same time.

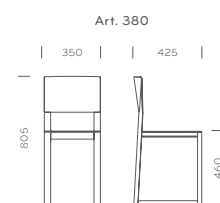

Art. 380 - Brera rovere tinto wengé e basamenti Ikon (Art. 865) con ripiani in stratificato nero.  
Brera chair wenge stained finish and Ikon table bases (Art. 865) with black solid laminate tops.





## Art. 380

Brera è in essenza di rovere con gambe in massello e sedile e schienale in tamburato. Disponibile nelle finiture rovere sbiancato, tinto wengé, tinto grigio chiaro o effetto anticato. Brera chair with solid oak structure, seat and back in hollow core. Bleached oak, wenge stained, light grey stained or vintage finish.

## Finiture: / Finishes:



W

RS

GC



V101

V102

V103







## Art. 380

Elegante e composta, Brera è caratterizzata da dimensioni contenute e al tempo stesso un grande comfort di seduto.  
Elegant and composed, Brera is characterized by small sizes and a great sitting comfort of the same time.





## Art. 382 - 386

Brera versione sgabello è disponibile in due altezze: 650 mm e 740 mm. In rovere sbiancato, tinto wengé, tinto grigio chiaro o effetto anticato.  
 Brera bar stool, two heights available: 650 mm and 740 mm. Bleached oak, wenge stained, light grey stained or vintage finish.

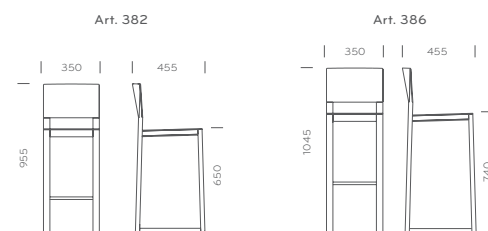

Finiture: / Finishes:

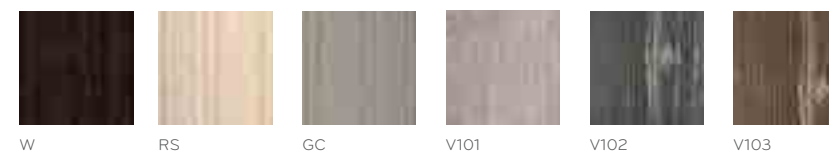

382



386





Art. 383 - 387 - 388

Lo sgabello Brera ha forme compatte e linee essenziali. Una seduta versatile che si adatta ai contesti più informali e alle esigenze di spazio ridotte. Realizzato in essenza di rovere.  
Brera barstool has compact shapes and essential lines. A versatile seat ideal for small and informal spaces. Made of solid oak.

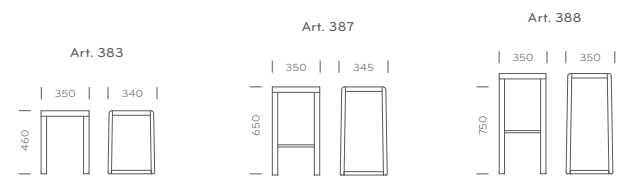

Finiture: / Finishes:



383



387



388



Art. 2700

Babila è una sedia che si muove con grande agilità tra tradizione e innovazione. Scocca in multistrato a spessore variabile anche con seduta imbottita, gambe in massello di frassino.  
Babila is a chair able to move along tradition and innovation with great agility. Plywood shell in variable thickness also with upholstered seat and solid ash legs.

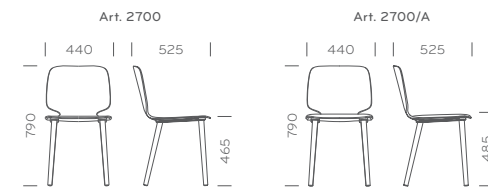

Finiture: / Finishes:



Art. 2710 - 2720

Babila è disponibile anche nella versione con telaio a 4 gambe in tubo d'acciaio Ø 16 mm o a slitta in tondino Ø 10 mm, cromato o verniciato. Disponibili le versioni con seduto imbottito.  
 Babila chair, four legs steel tube frame Ø 16 mm or sled steel rod frame Ø 10 mm, chromed or powder coated finish. Upholstered seat versions also available.

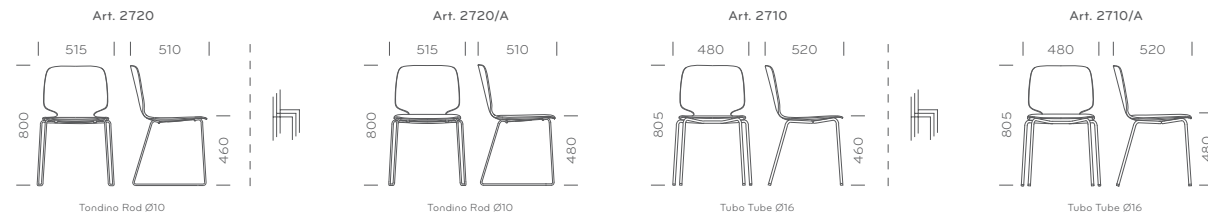

2710

2720/A



Art. 2702 - 2706

Lo sgabello in frassino Babila ha un look estremamente leggero. Le gambe affusolate si innestano nel sedile in multistrato senza l'aggiunta di parti di supporto, un elemento in pressofusione di alluminio garantisce l'appoggio per i piedi, incorniciando il legno e donandogli robustezza. Altezza 650 mm o 750 mm.

Babila ash wood barstool with an extreme lightweight look where the die-casted aluminium footrest is perfectly jointed to the legs. Height 650 mm or 750 mm.



Finiture: / Finishes:



FR



AN



GC



2706



2702



2706

Art. 2702 - 2706  
Lo sgabello Babila è in frassino sbiancato, tinto nero o tinto grigio chiaro. Il poggiatesta è in pressofusione di alluminio satinato o verniciato bianco e nero.  
Babila bar stool in bleached ash, black or light grey stained ash finish. Satinized or black and white powder coated die-casted aluminium footrest.



2706



2706



Design Michele Cazzaniga, Simone Mandelli, Antonio Pagliarulo

## Art. 2800 - 2801

Tivoli ripercorre il tema delle sedute in legno tradizionali conservando l'idea di comodità e convivialità come misura del gusto. Dall'incontro di artigianalità e innovazione tecnologica nasce una collezione dalle forme semplici, pensate per garantire il miglior comfort con naturalezza e grande rigore costruttivo.

Tivoli recalls the traditional wooden chairs, maintaining comfort and inspiring conviviality. From the right combination of craftsmanship and technological innovation a new collection is born; its soft shapes are designed to ensure the best comfort with great simplicity and executive rigour.

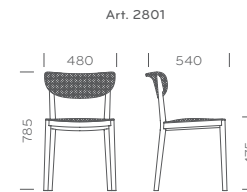
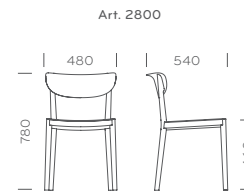

Finiture: / Finishes:



FR

AN



2800



2801

Art. 2805 - 2806

Il profilo essenziale integra alla perfezione gli elementi strutturali, la curvatura tridimensionale dello schienale ispira accoglienza. Il telaio è in essenza di frassino, il sedile in multistrato e lo schienale in multistrato tridimensionale. La collezione comprende sia la sedia che la poltrona. Il sedile e lo schienale possono essere imbottiti.

A clean design where the structural elements are perfectly integrated in the frame. The three-dimensional curves and the generous proportions of the back rest make Tivoli an ergonomic and elegant chair. The collection includes both the chair and the armchair. Upholstered seat and back available.

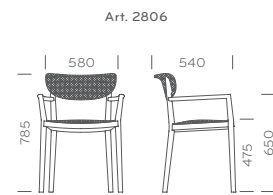
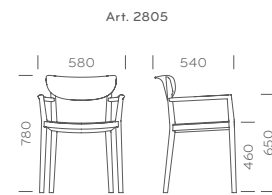

Finiture: / Finishes:



FR

AN



2805



2806

# 34 Malmö

Design Michele Cazzoniga, Simone Mandelli, Antonio Pagliarulo





reddot design award  
winter 2013



Art. 390 - 395

La struttura in massello di frassino di sedia e poltrona Malmö sostiene una scocca in multistrato curvato, sollevandolo ed esaltandone i particolari costruttivi. La sedia impilabile e la poltrona sono state pensate come oggetti accoglienti caratterizzati da linee morbide. Finiture in essenza di frassino sbiancato, tinto nero o tinto grigio chiaro.

Malmö chair and armchair ash timber frame supports a multilayer curved shell, with the aim to raise it enhancing its design particulars. The stackable chair and the armchair had been devised as comfortable items characterised by soft lines. Bleached ash, black or light grey stained finish.

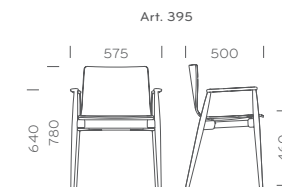
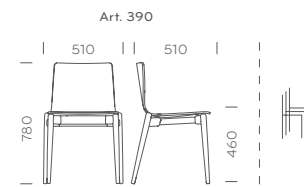

Finiture: / Finishes:



FR



AN



GC



390



390



395

Art. 391 - 396

Massimo comfort per le versioni sedia e poltrona Malmö con scocca imbottita, rivestita in tessuto, vera o finta pelle.  
Great comfort for Malmö chair and armchair upholstered version, fabric, mid grain or simil leather covering.

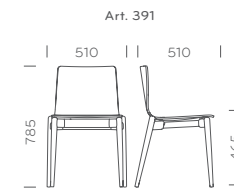
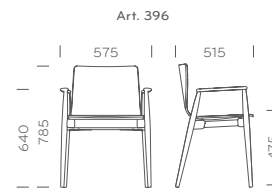

Finiture / Finishes:

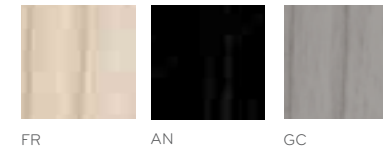

396



391



Art. 392 - 397

Sedia e poltrona Malmö sono disponibili anche con scocca rivestita in cuoio naturale o rigenerato con cuciture in tinta.  
Malmö chair and armchair, genuine or regenerated leather shell with matching stitches.

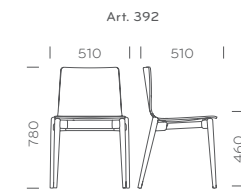
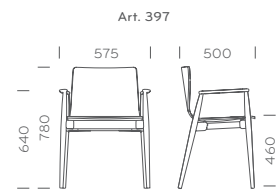

Finiture: / Finishes:



397



# 42 Malmö

Art. TML\_190X90

Il tavolo allungabile Malmö ha gambe in frassino, disponibile nelle finiture sbiancato o tinto nero, abbinato a ripiano in stratificato o impiallacciato. Disponibile anche nella versione fissa in 3 dimensioni: 900x900 mm (Art. TMLF\_90X90), 1400x900 mm (Art. TMLF\_140X90), 1800x900 mm (Art. TMLF\_180X90).

Malmö extendable table has ash wooden legs in bleached or black stained finish matched with solid laminate or ash veneered table top. Fixed versions in three dimensions also available: 900x900 mm (Art. TMLF\_90X90), 1400x900 mm (Art. TMLF\_140X90), 1800x900 mm (Art. TMLF\_180X90).









Art. 295 - 296 - 297

Poltrona Lounge con struttura in essenza di frassino, scocca in multistrato impiallacciato frassino, imbottita oppure rivestita in cuoio con cuciture in tinta.  
Lounge chair in solid ash wood, plywood shell ash veneered, upholstered or leather seat version with matching stitches.

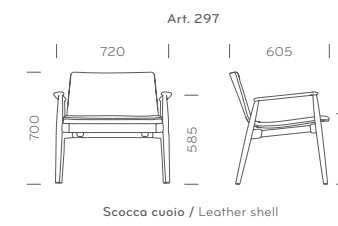
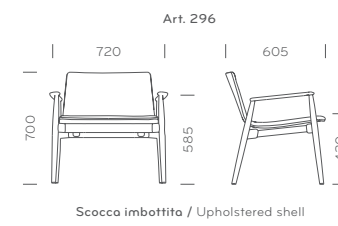
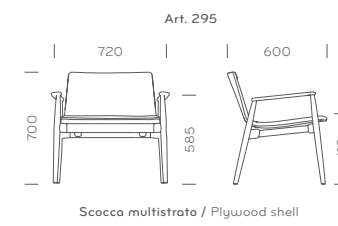

Finiture: / Finishes:



296



295





Art. 232 - 242 - 252 - 236 - 246 - 256

Sgabelli con struttura in essenza di frassino, scocca in multistrato impiallacciato frassino, imbottito oppure rivestita in cuoio con cuciture in tinta. Disponibili nelle altezze 650 mm e 750 mm.

Barstools in solid ash wood, plywood shell ash veneered, upholstered or leather seat version with matching stitches. Two heights available: 650 mm and 750 mm.

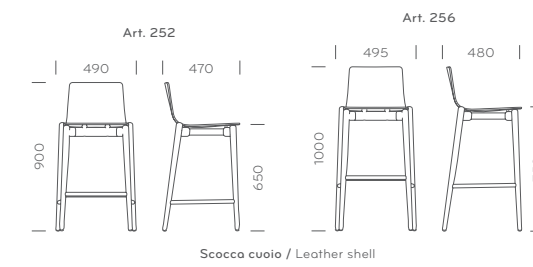
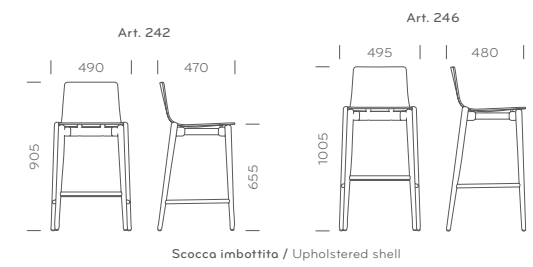
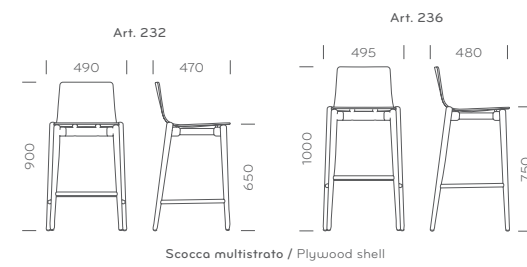

Finiture: / Finishes:

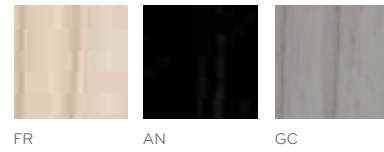

232



232



246

Art. MLT

Coffee tables con ripiano in mdf laccato, impiallacciato frassino o stratificato. Gambe in massello di frassino tornite.  
 Coffee tables with lacquered mdf top, ash veneered top or solid laminate tops. Tapered legs in ash wood.

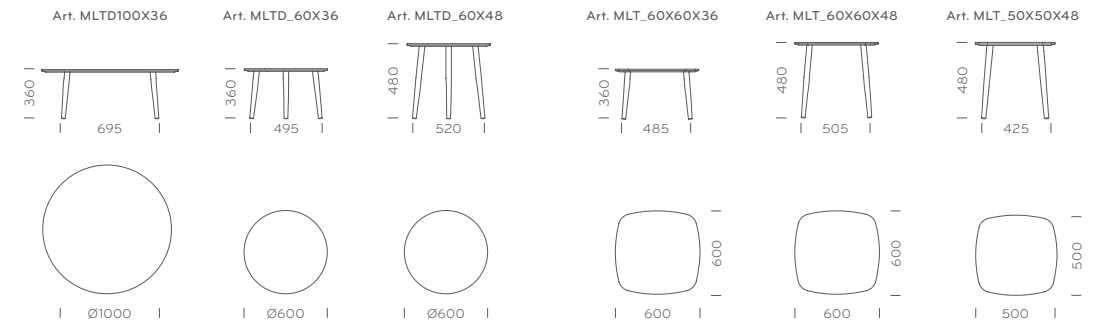

Art. MLT120X74X36

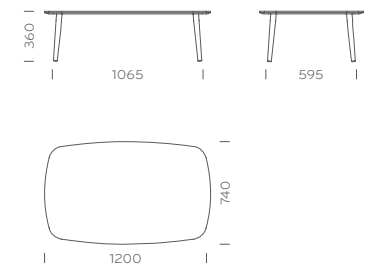

MLT120X74X36

Design Claudio Dondoli and Marco Pocci

Art. 905 - 904 - 904/F

Gliss si rinnova ed amplia la sua scelta di colori, strutture, materiali. Gliss Wood ha gambe in essenza di frassino, sbiancato o tinto nero, con scocca in policarbonato, tecnopolimero oppure rivestita in cuoio naturale.

Gliss, a contemporary star renovated by new material combinations for more versatile uses. Gliss Wood chair has bleached or black stained ash wooden legs with polycarbonate, technopolymer or upholstered genuine leather shell.

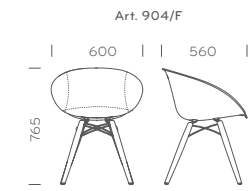
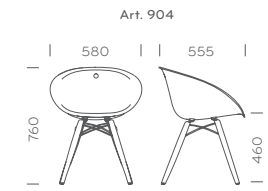
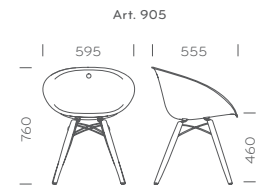

Finiture: / Finishes:



FR AN



905



904



904/F



## Art. 450

La sedia Feel ha un design essenziale e geometrico. Realizzata in essenza di rovere è disponibile in diverse finiture, anche tinte campione. Essential and geometric design for Feel chair. Made of oak wood, it is available in different finishes also stained on sample.

Design Pedrali R&D



Art. 450

Sedia Feel disponibile in rovere sbiancato, tinto wengè, tinto grigio chiaro, effetto anticato o laccato bianco poro aperto.  
 Feel chair available in bleached oak, wenge stained, light grey stained, vintage finish or open grains white lacquered oak.

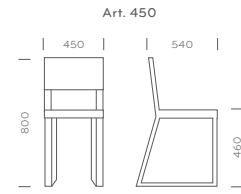

Finiture: / Finishes:



W RS GC

Disponibile solo per art. 450 / Available only for art. 450

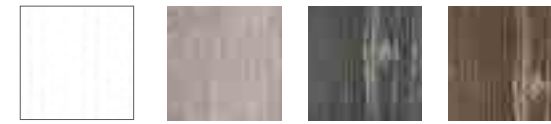

BI  
 Rovere laccato  
 bianco poro aperto  
 Open grains white  
 lacquered oak

Art. 451

La sedia Feel è disponibile anche nella versione con sedile imbottito in abbinamento a struttura in rovere sbiancato, tinto wengè o tinto grigio chiaro.  
 Available upholstered seat version in combination with bleached oak, wenge or light grey stained frame.

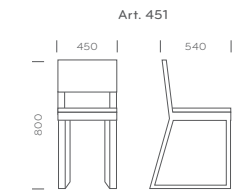

450



451



451



## Art. 450

Sedia Feel in rovere laccato bianco poro aperto.  
 Feel chair, oak open grains white lacquered finish.

Finiture: / Finishes:



BI  
 Rovere laccato  
 bianco poro aperto  
 Open grains white  
 lacquered oak



Art. 450/2 - 451/2

Feel poltrona è in rovere sbiancato, tinto grigio chiaro, effetto anticato o laccato bianco poro aperto. Disponibile anche la versione con sedile imbottito in abbinamento a telaio anche rovere sbiancato, tinto wengé o tinto grigio chiaro.

Armchair Feel in bleached oak, wenge stained, light grey stained, vintage finish or open grains white lacquered finish. Available upholstered seat version in combination with bleached oak, wenge or light grey stained frame.

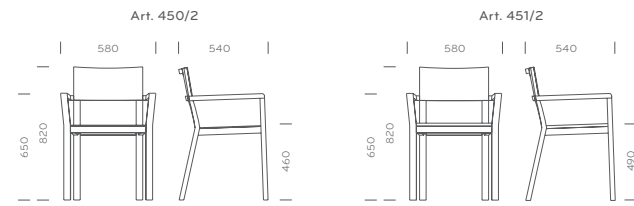

Finiture: / Finishes:

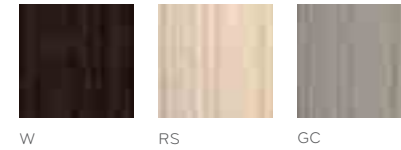

Disponibile solo per art. 450/2 / Available for art. 450/2 only



BI  
Rovere laccato  
bianco poro aperto  
Open grains white  
lacquered oak



450/2



451/2



# 62 Young

Design Pedrali R&D

Art. 420

Sedia Young realizzata in multistrato curvato che poggia su un telaio in massello di rovere. Resistente e allo stesso tempo leggera, peso solo kg 3,5.  
Young chair, curved multilayer shell and solid oak frame. Resistant and light, it weights only kg 3,5.

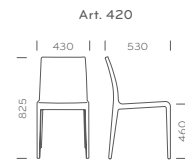

420



PEDRALI DYNAMIC DESIGN



## Art. 420

Young è disponibile in rovere sbiancato, tinto wengé, tinto grigio chiaro, effetto anticato laccato bianco poro aperto.  
 Young is available in bleached oak, wenge stained, light grey stained, vintage finish or open grains white lacquered oak.

## Finiture / Finishes:



W

GC

RS



BI

V101

V102

V103

Rovere laccato  
 bianco poro  
 aperto  
 Open grains white  
 lacquered oak



## Art. 425

Young versione poltrona mantiene la stessa eleganza e leggerezza della sedia da cui nasce. Le linee pulite ed asciutte che ne sottolineano funzionalità e comfort la rendono adatta all'inserimento negli ambienti più eterogenei. Young armchair keeps the same elegant look and weightlessness of the chair. Distinguished by clean and sober shapes which emphasize the great comfort and functionality and make it suitable for any furnishing environment.

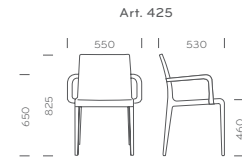

## Finiture: / Finishes:



Art. 421

Young+ è la versione impilabile, presentata nelle finiture rovere sbiancato, tinto wengé, tinto grigio chiaro o effetto anticato.  
Young+ is the stackable version, available in bleached oak, wenge stained, light grey stained or vintage finish.

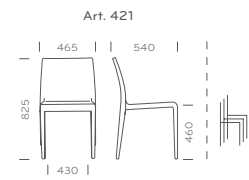

Finiture: / Finishes:



# 70 Young Soft

Art. 423 - 424

Sedia Young con parte frontale imbottita, rivestita in tessuto, vero o finta pelle.  
Disponibile anche nella versione impilabile.  
Young chair, upholstered front part in fabric, mid-grain leather or simil leather.  
Stackable version also available.

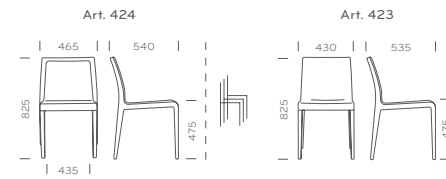

Finiture / Finishes:

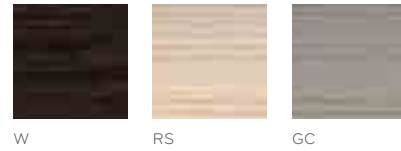

424



71

Art. 423 - Sedia Young e tavolo Inox (Art. 4402/AC) con ripiano stratificato Compact Full Colour bianco.  
Young chair and Inox table (Art. 4402/AC) with white Compact Full Colour solid laminate top.

## Art. 426

Sgabello Young realizzato in multistrato curvato che poggia su un telaio in massello di rovere. Poggiapiedi in tubo d'acciaio inox.  
 Young bar stool, curved multilayer shell and solid oak frame. Stainless steel tube footrest.

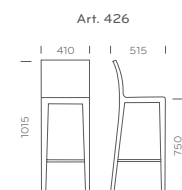

## Finiture / Finishes:

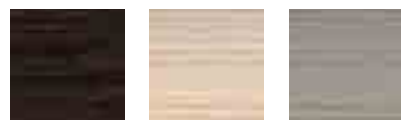

W

RS

GC



V101

V102

V103



## Art. 428

Sgabello Young con parte frontale imbottita, rivestita in tessuto, vera o finta pelle.  
Poggiopiedi in tubo d'acciaio inox.  
Young barstool, upholstered front part covered with fabric, simil-leather or mid grain leather. Stainless steel tube footrest.

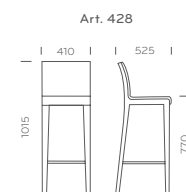

Art. 428 - Sgabelli Young e tavolo Tonda (Art. 4154\_AC)  
con ripiano in laminato.  
Young bar stools and Tonda standing table  
(Art 4154\_AC) with laminate top.



# Twig

Design Pedrali R&D

## Art. 429

Sedia Twig in rovere sbiancato, tinto wengé e tinto grigio chiaro oppure in faggio naturale o tinto nero. Schienale in tamburato su ambo i lati spessore 9 mm; imbottitura del sedile in tessuto, vero o finta pelle.

Twig chair bleached oak, wenge and light grey stained or beech wood, natural or black stained. Sandwich panel back on both sides, 9 mm thickness. Upholstered seat in fabric, simil-leather or mid grain leather.

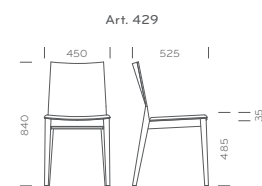

## Finiture: / Finishes:



RS



W



GC



FA



AN



Art. 429 - Sedia Twig e tavolo Inox (Art. 4402/RV\_RS) con colonna rovere sbiancato e ripiano impiallacciato rovere sbiancato.  
Twig chair and Inox Table (Art. 4402/RV\_RS) with bleached oak column and bleached oak veneered top.





Art. 429 - Sedia Twig e tavolo Inox (Art. 4402\_AC) con ripiano stratificato Compact Full Colour bianco.  
Twig chair and inox table (Art. 4402\_AC) with white Compact Full Colour solid laminated top.

Art. 429/2

La sedia Twig è disponibile anche nella confortevole versione con cuscino alto.  
Twig chair is also available with a comfortable thicker upholstered seat pad.

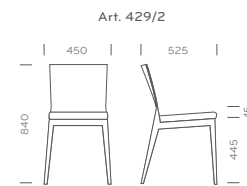

Finiture: / Finishes:



# Dress

Design Pedrali R&D

## Art. 530 - 535

Dress è una famiglia di sedute imbottite che comprende sedia con schienale basso, sedia con schienale alto e poltrona. La struttura e le gambe sono in rovere e i rivestimenti possono essere in tessuto, pelle o ecopelle. Sorprendono la snellezza delle gambe, che da sezione quadrata si rastremano verso il basso per diventare tonde, e la leggerezza della seduta in contrasto con l'eccezionale robustezza che le rende idonee per luoghi pubblici.

Dress is a family of upholstered chairs that includes armchairs and side chairs, with high or low back. Frame and legs are in oak wood and the upholstery can be in fabric, leather or simil leather. The slenderness of the legs, which are in square section taper down to become round, and the chair lightness surprise while in contrast to the exceptional strength that make them suitable for public areas.

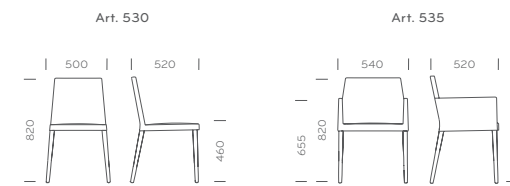

Finiture: / Finishes:



W

RS



530



535





## Art. 530 - 531

L'elegante versione della sedia con schienale alto rende Dress ideale per le sale ristorante degli hotel più esclusivi.

The elegant high backrest version makes Dress an ideal solution for dining rooms of the most exclusive hotels.

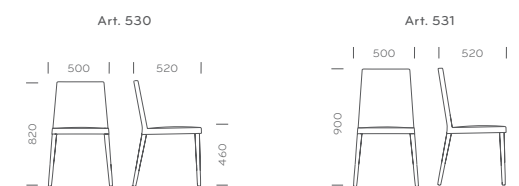

Finiture: / Finishes:



W

RS



530

531

Design Balutto Associati

## Art. 733

Un design minimale che individua uno stile senza tempo. Jackie è caratterizzata da un'elegante schienale alto e da gambe affusolate. Sofisticata ed armoniosa, ha struttura in rovere e sedile e schienale imbottiti rivestiti in tessuto, vera o finta pelle.

A minimal design recalls a timeless style. High backrest and thin tapered legs to make Jackie extremely elegant. Solid oak frame and different upholstery versions available.

Art. 733

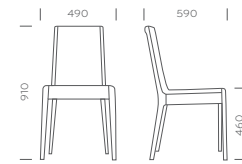

Finiture: / Finishes:



RS



W



GC



# 86 Sign

Design Daniele Lo Scalzo Moscheri



## Art. 455 - 457

Poltroncina Sign in massello di noce canaletto con imbottitura rivestita in tessuto. Disponibile anche in rovere sbiancato, tinto wengé o tinto grigio chiaro con rivestimento del sedile in vera o finta pelle. Massimo comfort per la versione con schienale imbottito. Sign armchair solid walnut frame with upholstery fabric covered. Available also in bleached oak, wenge or light grey stained oak frame with simil leather or mid grain leather seat covering. Very comfortable the upholstered back version.

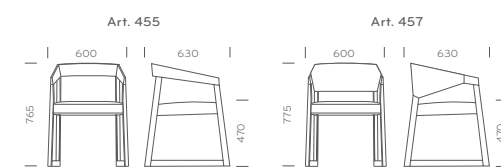

Finiture: / Finishes:

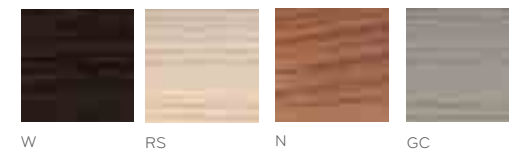

455



457





Art. TSU\_188X90 - Tavolo Surface finitura noce con poltroncine Sign (Art. 455).  
Surface table, walnut finish, with Sign armchairs (Art. 455).

Art. 455

Poltroncina Sign rovere tinto wengé con particolare sezione rastremata dei braccioli e sedile imbottito in vera pelle. Disponibile anche in rovere sbiancato, tinto grigio chiaro o in massello di noce canaletto.

Sign armchair, oak stained wenge frame and tapered armrests with mid grain leather covered seat. Available also in bleached oak finish, light grey stained finish or in solid walnut frame.





Poltroncina Sign (Art. 455) in rovere sbiancato con sedile in tessuto avorio e basamenti Zenith (Art. 4742).  
Sign armchair (Art. 455) in bleached oak finish with upholstered seat covered with ivory fabric and Zenith table bases (Art. 4742).



# 94 Surface

Design Daniele Lo Scalzo Moscheri

## Art. TSU\_188X90

Tavolo Surface allungabile, impiallacciato rovere, tinto wengé, tinto wengé nero, impiallacciato noce o in faggio laccato bianco goffrato. Il terminale e le gambe sono a forte spessore con sezione rastremata, donano quindi leggerezza formale mantenendo le doti di resistenza e stabilità del tavolo. Le guide telescopiche in alluminio permettono la facile estrazione delle due allunghe, ciascuna delle quali ha lunghezza di 500 mm. Il particolare sistema di ruote permette di far scivolare le gambe che rimangono sempre all'estremità del tavolo, consentendo la massima funzionalità degli spazi. Surface extendable table, oak veneered, wenge and black wenge stained or walnut veneered finish or white matt finish lacquered beech wood. Thick and tapered legs give to the table both stability and a touch of lightness. Aluminium sliding rail guides, two leaves (500 mm length each) allow to extend easily the table up to 2.88 meter. The wheeling system makes the legs slide towards the external sides of the table, allowing maximum functionality.

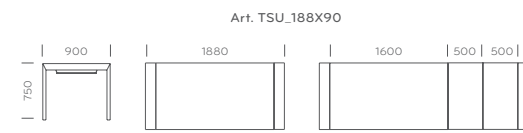

### Finiture: / Finishes:



N



W



NE



BI  
Faggio laccato  
bianco goffrato  
White matt finish  
lacquered beech



95



# 96 Allure Sedia

Design Pedrali R&D

Art. 735

Allure versione sedia è caratterizzata da linee armoniche e morbidi profili. Leggera e resistente, ha gambe in massello di rovere disponibili nelle finiture rovere sbiancato o tinto wengè e imbottitura in tessuto, vero o finto pelle.  
Harmonic shapes and soft profiles for Allure chair. Lightweight and resistant, solid oak legs in bleached oak or stained wenge finish and upholstered seat and back in fabric, simil leather or mid grain leather.

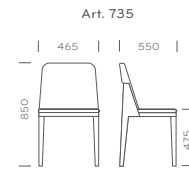

Finiture: / Finishes:



RS

W



Art. 737 - 738

La poltroncina Allure ha angoli raggianti e forme avvolgenti. La morbida imbottitura è racchiusa da un sottile guscio in legno disponibile nelle finiture rovere sbiancato o tinto wengé. Struttura in tubo d'acciaio a slitta o su quattro gambe.  
 Allure armchair featured by rounded profiles and embracing shapes. Soft upholstery on wooden shell in bleached oak or wenge stained finish. Steel tube sleight shape or four legs frame.

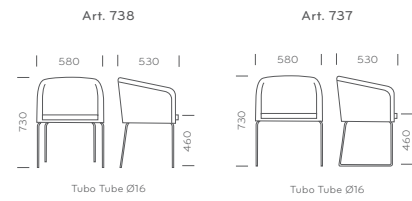

Finiture: / Finishes:



738



737



# 100 Leila

Design Maurizio Manzoni and Roberto Tapinassi

## Art. 681

Forma monolitica e geometrica per Leila, elegante poltroncina imbottita pensata per il ristorante e l'ufficio. Caratterizzata da angoli smussati e da un'immagine morbida e confortevole, Leila ha la scocca imbottita rivestita in tessuto, vera o finta pelle e le gambe in essenza di rovere nelle finiture sbiancato, tinto wengè o laccato bianco. Leila armchair, soft and elegant, with its rigorous and geometrical shape, is conceived for restaurants and offices. Featured by rounded corners and embracing shape, Leila armchair is upholstered in fabric or simil leather or mid grain leather. Frame in bleached oak, wenge stained or open grains white lacquered oak.

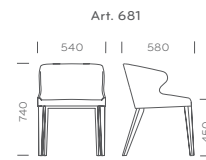

### Finiture: / Finishes:



BI  
Rovere laccato  
bianco poro  
aperto  
Open grains  
white  
lacquered oak



Art. 452

Sedia Elle con gambe in massello rastremate verso il basso. Le gambe posteriori s'innestano nello schienale, mantenendo una continuità di forma tra le parti. Lo schienale, avvolgente, è realizzato in tamburato. Il sedile imbottito, ad alto spessore è un dettaglio che la rende oltre che confortevole adatta all'inserimento in ambienti di prestigio. Elle chair has tapered solid oak legs with unique outlined shape that build into the back of the chair keeping harmony in the shapes. The embracing back is made in sandwich panel, the thick upholstered seat makes the chair highly comfortable and suitable for prestigious locations.

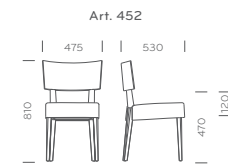

Finiture: / Finishes:



Art. 453

Elle è disponibile anche nella versione con sedile imbottito a basso spessore. Telaio in rovere sbiancato, tinto wengé o tinto grigio chiaro.  
 Elle chair is also available with thin upholstered seat. Bleached oak, wenge or light grey stained finish.

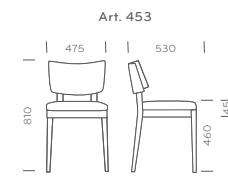

Finiture: / Finishes:

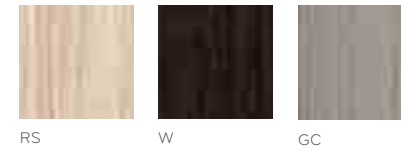

Design Enrico Franzolini

## Art. 525

Jil è un programma di sedute imbottite pensate per il contract di qualità, per l'hotellerie e l'hospitality. La struttura è in rovere sbiancato, color tabacco o tinto grigio chiaro. Il rivestimento in tessuto, vera o finta pelle offre grandi possibilità di personalizzazione. Massima attenzione all'ergonomia della seduta per le versioni poltrona e poltrona lounge.

Jil is an upholstered chair collection designed for the quality contract market, for hotellerie and hospitality. Solid oak frame in bleached, tobacco or light grey finish. The wide range of fabrics, leathers or eco leathers, offer great customization possibilities. Great attention to the ergonomics of the seat for armchair and lounge armchair versions.

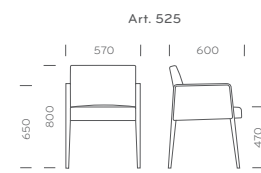

Finiture: / Finishes:



RS



W



GC



Art. 525 - Poltrona Jil e tavolo Inox verniciato nero (Art. 4402\_NERO)  
con ripiano in stratificato nero.  
Jil armchair and black powder coated Inox table (Art. 4402\_NERO)  
with black solid laminate top.



## Art. 526

Jil versione sgabello ha telaio in massello di rovere, sbiancato, tinto tabacco o tinto grigio chiaro, con seduto e schienale imbottiti.  
Jil bar stool, solid oak frame in bleached oak, tobacco or light grey stained finish, upholstered seat and back.

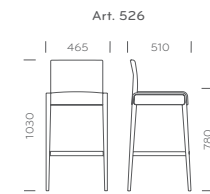

Finiture: / Finishes:



RS



W



GC



526



Art. 520

Jil nella versione sedia coniuga la piacevolezza tattile ed il calore del legno di rovere con il comfort e la qualità delle imbottiture e dei rivestimenti in tessuto, vera o finta pelle.

Jil chair version combine the tactile amenity and the warmth of oak with comfort and quality of the upholstery in leather or fabrics.

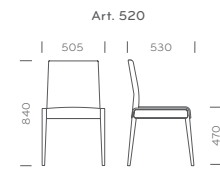

Finiture: / Finishes:



Art. 521

Jil poltrona lounge, raffinata scelta per le soluzioni contract di alta classe.  
Disponibile in rovere sbiancato, tinto tabacco o tinto grigio chiaro in abbinamento a diversi tessuti e pelli.  
Jil lounge armchair, elegant choice for high-class contract solutions.  
Available in bleached oak, tobacco or light grey stained finishes combined with different fabrics and leathers.

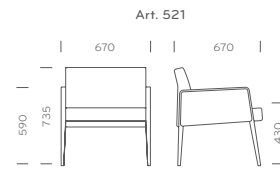

Finiture: / Finishes:



RS W GC



Art. 740 - 746

Poltrona e divanetto Box in tamburato di rovere, sbiancato o tinto wengé. Seduta, schienale e fianchi imbottiti. Telaio in tubolare d'acciaio 20x20 mm satinato. Lo schienale confortevole è supportato da cinghie elastiche.  
Box armchair and sofa, sandwich panel shell in bleached oak or stained wenge finish. Upholstered seat, back and sides. Satinized 20x20 mm steel tube frame. Upholstered backrest with elastic belts.

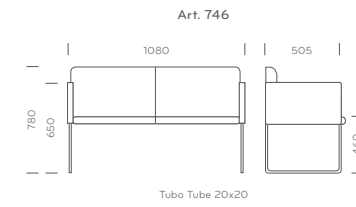
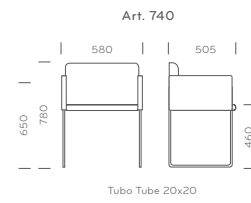

Finiture: / Finishes:



RS



W



740



746



Art. 740 - Poltroncina Box e tavolo Inox (Art. 4402\_AC) con ripiano impiallacciato rovere tinto wengé.  
Box armchair and Inox table (Art. 4402\_AC) with oak veneered wenge stained top.

Art. 747

Sgabello Box in tamburato di rovere sbiancato o tinto wengé. Seduta, schienale e fianchi imbottiti. Struttura in tubo d'acciaio satinato sezione 20x20 mm.  
 Box bar stool, sandwich panelled shell in bleached oak or stained wenge finish. Upholstered seat, back and side. Satinized 20x20 mm steel tube frame.

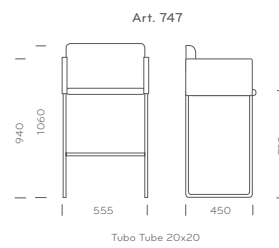

Finiture: / Finishes:

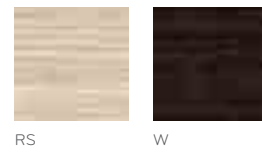

## Art. 742

Poltroncina Box con gambe in massello di rovere rastremate verso il basso, nelle versioni sbiancato o tinto wengé. Seduta, schienale e fianchi imbottiti in tessuto, vera o finta pelle.  
Box armchair, solid oak tapered legs, bleached oak or stained wenge version. Back, seat and sides upholstered in fabric, simil-leather or mid grain leather.

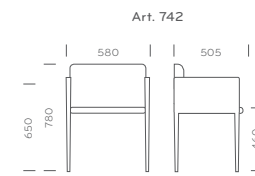

Finiture: / Finishes:



RS



W



# 122 Box Lounge

Art. 741

Poltrona Box Lounge in tamburato di rovere. Seduta, schienale e fianchi imbottiti in tessuto, vera o finta pelle. Telaio in tubolare d'acciaio mm 20x20 satinato.  
Box Lounge armchair sandwich panel frame oak veneered. Upholstered seat, back and sides. Satinized 20x20 mm steel tube frame.

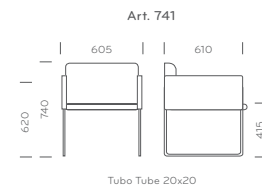

Finiture: / Finishes:



RS

W



Design Pedrolì R&D

Art. 431 - 430

Sedia Glam con gambe in massello di rovere e schienale in tamburato nelle versioni rovere sbiancato o tinto wengé. Seduto imbottito supportato da cinghie elastiche. Sotto la versione impilabile (Art. 431).  
 Glam chair, solid oak legs and sandwich panel back, bleached oak or stained wenge version. Upholstered seat with elastic belts. Stackable version in picture below (Art. 431).

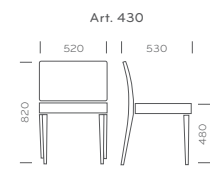
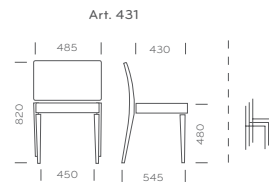

Finiture: / Finishes:



431



430

Art. TE\_178X90 - Tavolo Exteso e sedia Glam Art. 430  
 Exteso table and Glam chair Art. 430





432

Art. 432 - 433

Sedia Glam con schienale in canna intrecciata su ambo i lati e telaio in rovere sbiancato o tinto wengé. Disponibile nella versione impilabile (Art. 433).  
 Glam chair both sides woven cane back and bleached oak or stained wenge frame. Available stackable version (Art. 433).

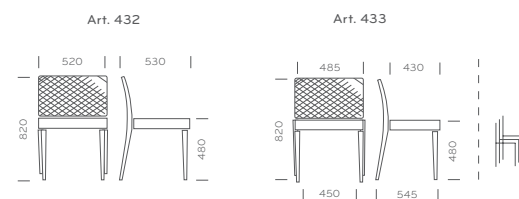

Finiture: / Finishes:

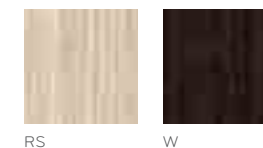

Canna: / Cane:

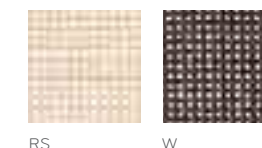

433



Art. 435

Sedia Glam con sedile e schienale imbottiti rivestiti in tessuto, vero o finta pelle.  
 Telaio in rovere sbiancato o tinto wengé. Impilabile.  
 Glam chair upholstered seat and back version, covered with fabric, simil-leather or mid grain leather. Bleached oak or stained wenge frame. Stackable.

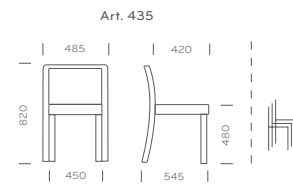

Art. 435 - Glam e tavoli Inox (Art. 4402/AC) con ripiani impiallacciati rovere tinto wengé.  
 Glam chair and Inox tables (Art. 4402/AC) with oak veneered wenge stained tops.

Design Pedrali R&D

Art. 758

Sedia Polo con sedile e schienale imbottiti rivestiti in tessuto.  
Gambe in massello di rovere sbiancato o rovere tinto wengè.  
Polo chair, upholstered seat and back covered with fabric.  
Solid oak legs in bleached oak, or oak wenge stained.

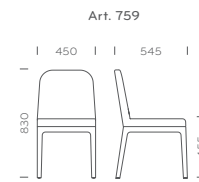
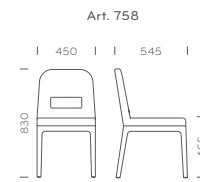

Finiture: / Finishes:

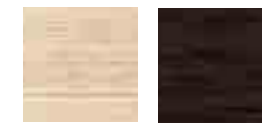

RS

W



758



758





Sedia Polo (Art. 759) con gambe in massello di rovere tinto wengé e rivestimento in tessuto. Tavolo Exteso in rovere tinto wengé (Art. TE\_178X90) e lampada da terra L002ST nella versione monocromatica nera.  
Polo chair (Art. 759), wenge stained solid oak legs and fabric covering. Exteso table in wenge stained finish (Art. TE\_178x90) and floor lamp L002ST in black monochromatic version.

Design Roberto Semprini

Art. 755

Sedia Gilda con gambe in massello di rovere sbiancato, tinto wengé, laccato nero o bianco.  
Gilda chair with solid oak legs, bleached oak, stained wenge stained, black or white lacquered.

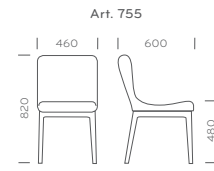

Finiture: / Finishes:



RS W NE BI





Art. 755 - Sedie Gilda con gambe in massello di rovere laccato bianco. Tavolo Togo nella versione monocromatica bianca con ripiano quadrato e lampade a sospensione L002S.  
Gilda chair, white laquered solid oak legs. Togo table in white monochromatic version with square top and L002S suspension lamp.

Art. 755

Sedia Gilda con sedile e schienale imbottiti rivestiti in lana. Gambe in massello di rovere sbiancato, tinto wengé, laccato nero o bianco.  
Gilda chair, wool upholstered seat and back. Solid oak legs, bleached oak, wenge stained, black or white lacquered.



Art. 470+472 - Wow tavolino in polietilene con ripiano.  
Polyethylene Wow low table with top.

Art. 4401/LU - Tavoli Inox con ripiani impiallacciati rovere sbiancato.  
Inox tables with bleached oak veneered tops.

Design Pedrali R&D

Art. 750

Sedia Zen con scocca in tamburato impiallacciato rovere sbiancato, tinto wengé o effetto anticato. Gambe anteriori in rovere massello; gambe posteriori in tubolare d'acciaio 20x20 mm satinato o cromato. Impilabile.  
Zen chair, panelled oak veneered shell, bleached oak, stained wenge or vintage finish. Front legs in solid oak, back legs in satinized or chromed 20x20 mm steel tube. Stackable.

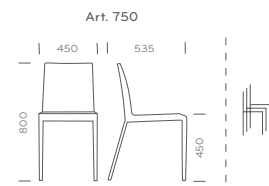

Finiture: / Finishes:





Art. 750

Sedia Zen e tavolo Magic Art. TM\_200X90 con struttura in acciaio inox e vetro temperato, allungabile.  
Zen chair and Magic table Art. TM\_200X90 with stainless steel structure and extensible tempered glass top.



# 144 Apple

Design Marco Pucci and Claudio Dondoli

## Art. 760

Apple è composta di due parti in tamburato impiallacciato, abbinata da una lamina di alluminio che permette di accostare sedile e schienale in materiali diversi, rovere sbiancato e tinto wengé combinati a scelta.

Apple armchair, wooden seat composed by two panelled foam veneered parts, bleached oak or wenge stained finish. It is possible to combine them differently thanks to an aluminium plate.

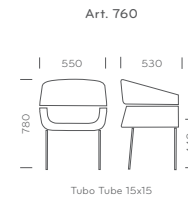

Finiture: / Finishes:



RS W

## Art. 760.3

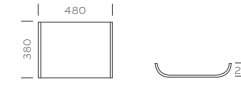

## Art. 764

Apple girevole su base in acciaio inox, con meccanismo di ritorno automatico.  
Swivel Apple with stainless steel base, automatic return mechanism.

## Art. 764

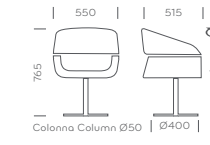

760



760 + 760.3



764

Art. 762 - 760.3

Poltroncina Apple con scocca in rovere tinto wengé, disponibile anche in rovere sbiancato. Il profilo di forte spessore diviene bracciolo ergonomico. Versione con telaio a quattro razze in tubo d'acciaio. Disponibile il cuscino in tessuto o pelle (Art. 760.3).  
 Apple armchair, stained wenge or bleached oak shell. Thick edge becomes an ergonomic armrest. Round steel spider frame version. Available fabric or mid grain leather cushion (Art. 760.3).

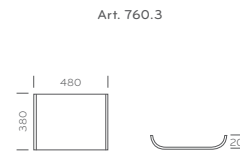
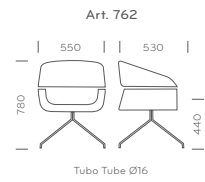

Finiture: / Finishes:

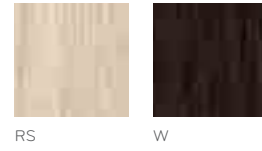

Art. 762 - Apple su razze e tavoli Inox modello (Art. 4411/LU) con ripiano rovere impiallacciato wengé.  
 Apple armchair on spider frame and Inox tables (Art. 4411/LU) with oak veneered wenge stained tops.

# 148 Apple Plus

Art. 770

Apple Plus con fianchi in tamburato, rovere sbiancato o tinto wengé. Seduta imbottita in pelle o in tessuto supportata da cinghie elastiche. Munito di ruote.

Apple Plus, sandwich panel sides, bleached oak or stained wenge version. Upholstered seat with elastic belts covered with fabric or mid grain leather. Four castors frame.

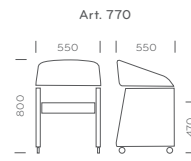

Finiture: / Finishes:



RS

W



Design Pedrali R&amp;D



Art. TE\_178X90 - Tavolo Exteso impiallacciato rovere tinto wengé e poltroncine Apple (Art. 762).  
Exteso table oak veneered stained wenge and Apple armchairs (Art. 762).



Art. TE\_178X90 - Tavolo Exteso in faggio laccato bianco goffrato e poltroncine Plus (Art. 630).  
Exteso table, white matt finish laquered beech wood and Plus armchair (Art. 630).

Art. TE\_178X90

Tavolo Exteso allungabile in rovere sbiancato, tinto wengé o faggio laccato bianco goffrato. Piano d'appoggio in tamburato, gambe in massello dalla forma quadrata rastremata verso terra. Le guide telescopiche in alluminio permettono la facile estrazione delle due allunghe, ciascuna delle quali ha lunghezza di 500 mm. Il particolare sistema di ruote permette di far slittare le gambe che rimangono sempre all'estremità del tavolo, consentendo la massima funzionalità degli spazi.

Exteso extendable table, veneered bleached oak or stained wenge, or white matt finish laquered beech wood. Sandwich panel top, solid square and tapered legs. Aluminium sliding rail guides and two leaves (500 mm length each) allow to extend easily the table up to 2.78 meter. The wheeling system makes the legs slide towards the external sides of the table, allowing maximum functionality.

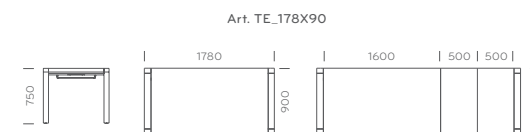

Finiture: / Finishes:



RS



W



BI  
Faggio  
laccato bianco  
goffrato  
White matt  
finish laquered  
beech





Design Marco Pocci and Claudio Dondoli

Art. P10001 - P10002 - P10005 - P10006

Due parentesi tonde che prendono forma per creare elementi geometrici. Contenitore a giorno o comodo piano, coffee table o comodino: Parenthesis è un elemento d'arredo versatile adatto a diversi contesti. I fianchi sono in multistrato di rovere mentre i ripiani in stratificato. Proposto in quattro versioni è disponibile in diverse finiture e combinazioni di colore per dare carattere agli ambienti in cui è inserito.

Two round brackets that create geometric elements. Coffee table or useful top, day container or bedside table: Parenthesis is a versatile furniture object suitable for different contexts. The lateral sides are made of plywood oak and the tops of solid laminate. The four versions of Parenthesis are available in different finishes and colour combinations, so to give character to the environments in which it is inserted.

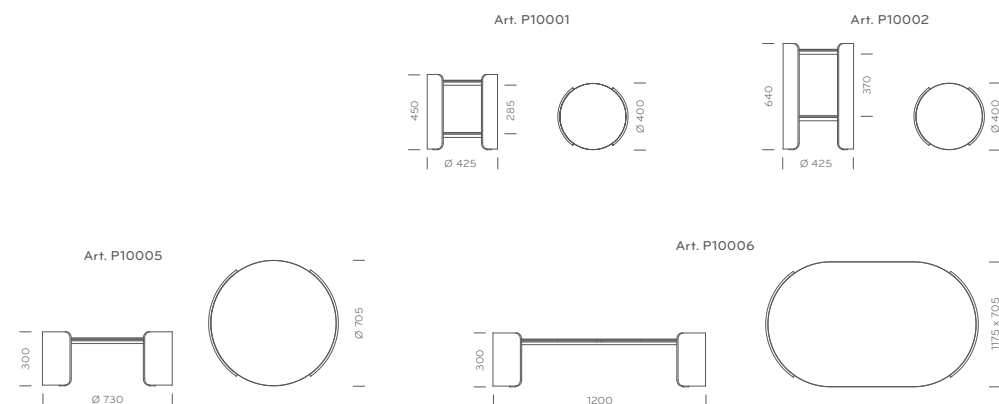

finitura struttura:  
frame finish:



RS AN GC BI

colori ripiano:  
top colours:

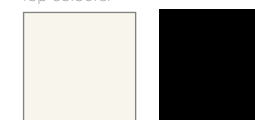

CFP\_BI FNP\_NERO

colore ripiano MDF:  
MDF lacquered top colour:



GC



P10001



P10002

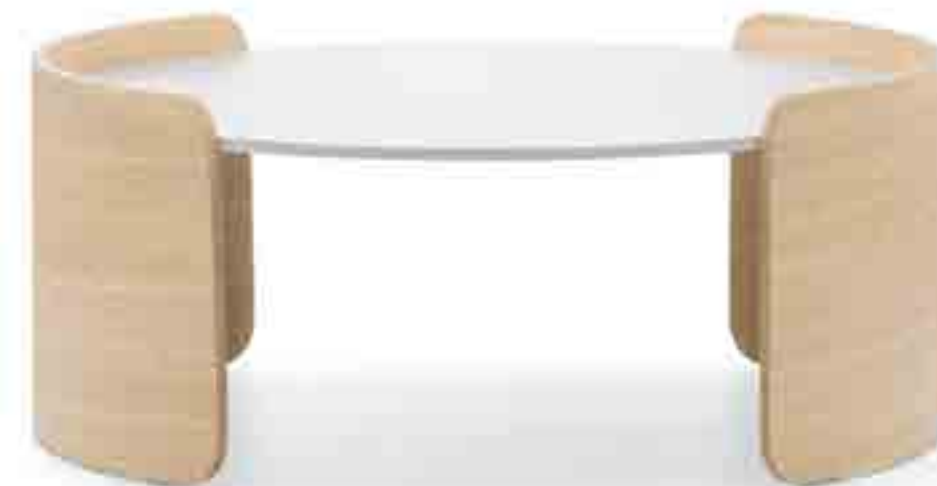

P10005



# Arki-Table Wood

Design Pedrali R&D

## Art. ARKW

Look industriale, proporzioni rigorose e versatilità nell'utilizzo. Arki-Table Wood ha le gambe in massello di rovere, il profilo-cornice in estruso di alluminio e il ripiano in stratificato.  
Industrial look, rigorous shapes and versatility. Arki-Table Wood has legs in solid oak, extruded aluminium frame and solid laminate top.

Art. ARKW200/240/300X100



Art. ARKW139X139

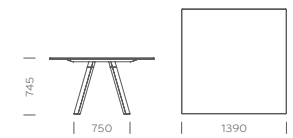

finitura gambe:  
legs finish:



RS

colori ripiano:  
top colours:



Bianco White



Nero Black

Art. ARKW240/300X120

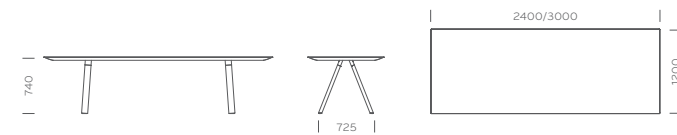

Art. ARKWD139

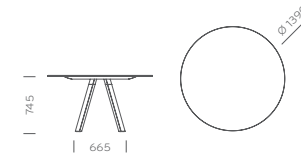

Art. ARKW240/300X120CC

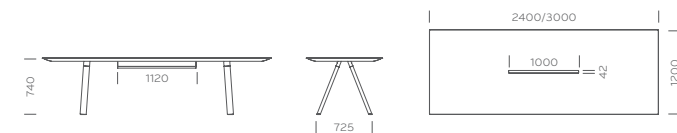

Art. ARKWD159

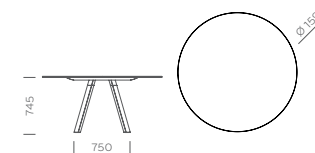

ARKW300X100

## Apple



AC / Acciaio Inox  
Satinato  
Brushed s/steel



ST / Acciaio satinato  
Satinized steel



CR / Acciaio cromato  
Chromed steel

## Zen - Allure



CR / Acciaio cromato  
Chromed steel



ST / Acciaio satinato  
Satinized steel

## Babila



CR / Acciaio cromato  
Chromed steel



ST / Alluminio satinato  
Solo per Art. 2702,  
2706  
Satinized aluminium  
Only for Art. 2702,  
2706



BI / Verniciato bianco,  
finitura goffrata  
White powder coated,  
textured finish



NERO / Verniciato nero,  
finitura bucciata  
Black powder  
coated, hammered  
finish



RU / Verniciato ruggine,  
finitura goffrata  
Rust powder  
coated, textured  
finish



TR / Verniciato  
trasparente opaca,  
finitura liscia  
Transparent matt  
powder coated,  
smooth finish



AG / Verniciato alluminio,  
finitura goffrata  
Aluminium powder  
coated, textured  
finish



GN / Verniciato grigio  
naturale, finitura  
goffrata  
Natural grey  
powder coated,  
textured finish

## Box - Box Lounge



ST / Acciaio satinato  
Satinized steel



The mark of  
responsible forestry

Cerca i prodotti certificati FSC™  
Look for FSC™ certified products

Pesi, dimensioni e colori sono indicativi. Pedrali si riserva la facoltà di apportare modifiche o migliorie senza alcun preavviso.

Weight, sizes and colours are approximate. Pedrali reserves the right to modify or upgrade the product without prior notice.

Tutte le collezioni Pedrali sono protette nel mondo dal diritto di proprietà industriale e da brevetti registrati.

All Pedrali collections are protected throughout the world by industrial design, patent and copyright registries.

Catalogo WoodCollection | Edizione Dicembre 2014

Progetto grafico e art direction: Borgo Creativo

Photo: Ezio Manciuca + Davide Cerati + Studio Odeon + Ottavio Tomasini + Fabrizio Carraro + Leo Torri  
Beppe Brancato + Ángel Luis Baltanas

Styling: Cristina Pasini

Stampa: Intese Grafiche

Copyright Pedrali 2014